



## MARINE PRODUCT DATA SHEET

OEM: 357-021-01 (380 GPH)

AFTERMARKET: 357-021-11 (380 GPH)

For a complete package combined the Piranha Series Bilge pumps with our reliable automatic float switch. Our tough, high density nylon housing and heavy duty water cooled motor gives the SHURflo Bilge Pump unparalleled reliability. Adding our non-mercury, solid state controlled switch with 2 second time delay ensures easy removal of water from the bilge. Easy Installation and removable cartridge for easy cleaning.

### TYPICAL APPLICATIONS

12V Marine Bilge Water Evacuation. For other applications, Contact SHURflo.

### PUMP

Type: Centrifugal Pump  
Port: 3/4" Barb  
Liquid: 130 °F [54 °C] Max  
Prime: Flooded Inlet  
Run Dry: No

### ELECTRICAL

Motor: 12VDC Permanent Magnet, Continuous Duty  
Protection: External Fuse  
Pump Leads: 6 ft (1.8M) Tinned, 16 AWG  
Switch Leads: 6 ft (1.8M) Tinned, 18 AWG  
Fuse: 2.5 Amp Recommended  
Control: Solid State Control with two second time delay, engaging only when water is in the bilge.

### MATERIALS

Housing: High Strength Nylon  
Impeller: High Strength Nylon  
Hardware: Stainless Steel

### APPROVALS

Ignition Protected, CE, ISO 8846

### WARRANTY

3 Year Limited Warranty  
See SB-1050 For Full Warranty Details

### SHIPPING

Net Weight (Boxed): 1.25 Lb [0.56 Kg] each  
Carton Weight: 30 Lb [13.6 Kg]  
Pumps in Carton: 24  
Carton Size: 24"L x 18"W x 11" H [61 cm x 46 cm x 28 cm]

### RELATED DOCUMENTS

Catalog: MS-030-140  
Installation Manual: 911-593-00  
Maintenance: 911-593-00  
Applications Spec Guide: MS-020-005  
Warranty: SB-1050

### Replacement Kits

94-005-00

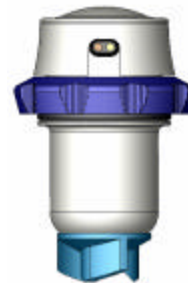

94-007-00



PERFORMANCE @ 13.6V DC

PRESSURE		FLOW		CURRENT
METERS	FT OF HEAD	GPH	LPH	AMPS
0.0	0	424	1604	1.96
1.20	4	303	1146	1.82
2.40	8	147	556	1.60

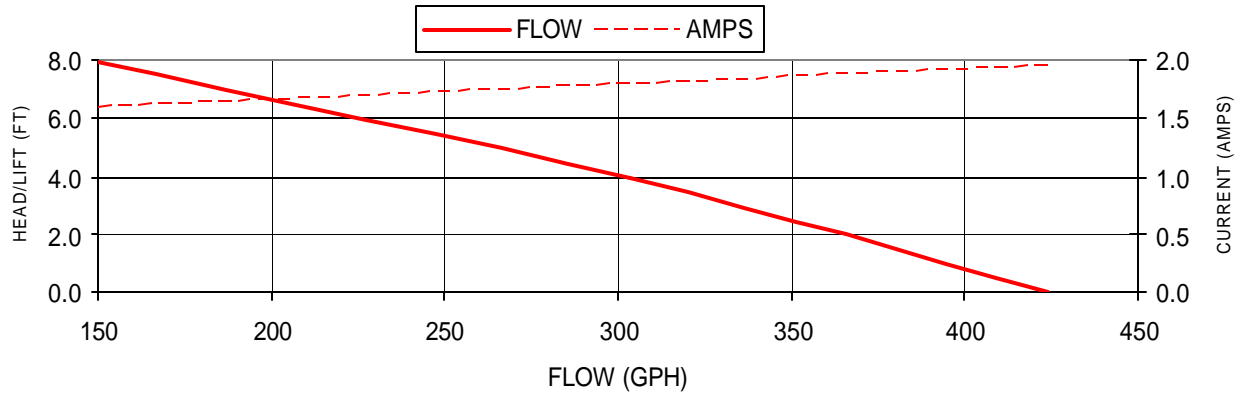

DIMENSIONS [mm]

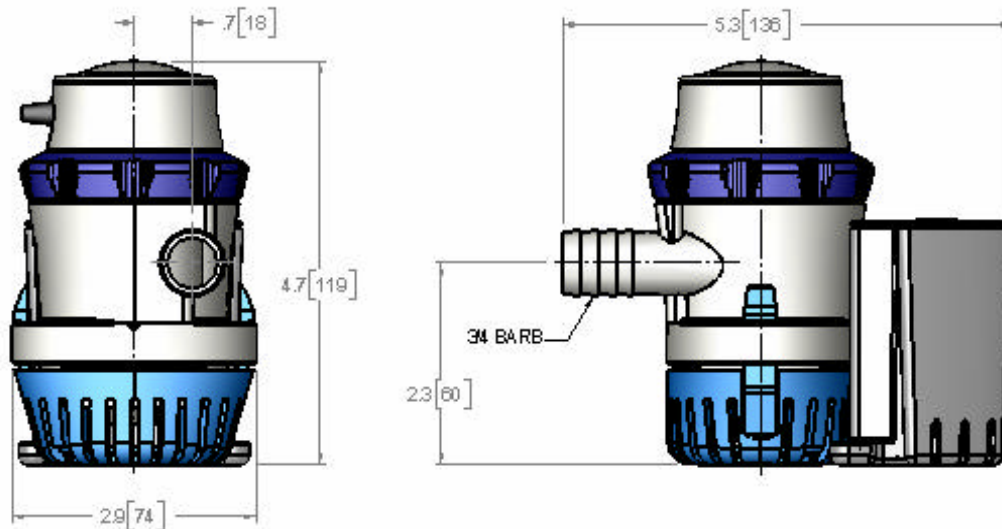

\*ISO Registered Facility

SHURflo reserves the right to update specifications, prices, or make substitutions.



SHURflo, LLC\*  
 5900A Katella Ave.  
 Cypress, Ca. 90630  
 Phone: 800 854 3218  
 Fax: 562 795 7554  
 Shipping: 5900C Katella Ave.  
 Cypress, Ca. 90630

SHURflo East  
 52748 Park Six Court  
 Elkhart, IN 46514-5427  
 Phone: 800 854 3218  
 Fax: 574 264 2169  
 Http://www.shurflo.com  
 © 2001

SHURflo Ltd.\*  
 Unit 5, Sterling Park  
 Gatwick Road, Crawley  
 West Sussex, RH10 9QT  
 United Kingdom  
 Phone: 0044 (0) 1293 424 000  
 Fax: 0044 (0) 1293 421 880