



SMART SENSOR™ 4.0 Installation & Operation Manual

IMPORTANT

READ INSTRUCTIONS ENTIRELY BEFORE INSTALLING THE SMART SENSOR 4.0

Congratulations! You have purchased the finest potable water pump in the industry. The Smart Sensor 4.0 has been designed and engineered to provide you with “just like home” water flow.

MOUNTING

- Mount pump within 6 feet of tank for best performance.
- Mount pump for easy access if maintenance is required.
- Mount pump in a space of two cubic foot unless adequate ventilation is provided.
The pump may be mounted in any position.
- Choose a solid surface that will not amplify pump vibration. Heat sink must be free and have air flowing across.
- The mounting feet are intended to isolate the pump from the mounting surface; over tightening, or use of oversized screws will reduce ability to isolate vibration/noise.

ELECTRICAL

- The pump should be on a dedicated (individual) circuit protected by the specified fuse indicated on the motor label.
- A U/L approved marine duty switch (ignition protected) rated for 15 amps or higher is recommended, and must interrupt current flow on the positive (+ red) lead.
- Pump draws 15 milliamps when pump switch is on, even when pump is not running.

WARNING: 12V PUMPS

Test incoming power with a multimeter to check voltage polarity (red = +). Red pump wire **MUST** be connected to positive power or permanent damage to controller will result!!! Failures of these type are not covered under product warranty.

TYPICAL INSTALLATION

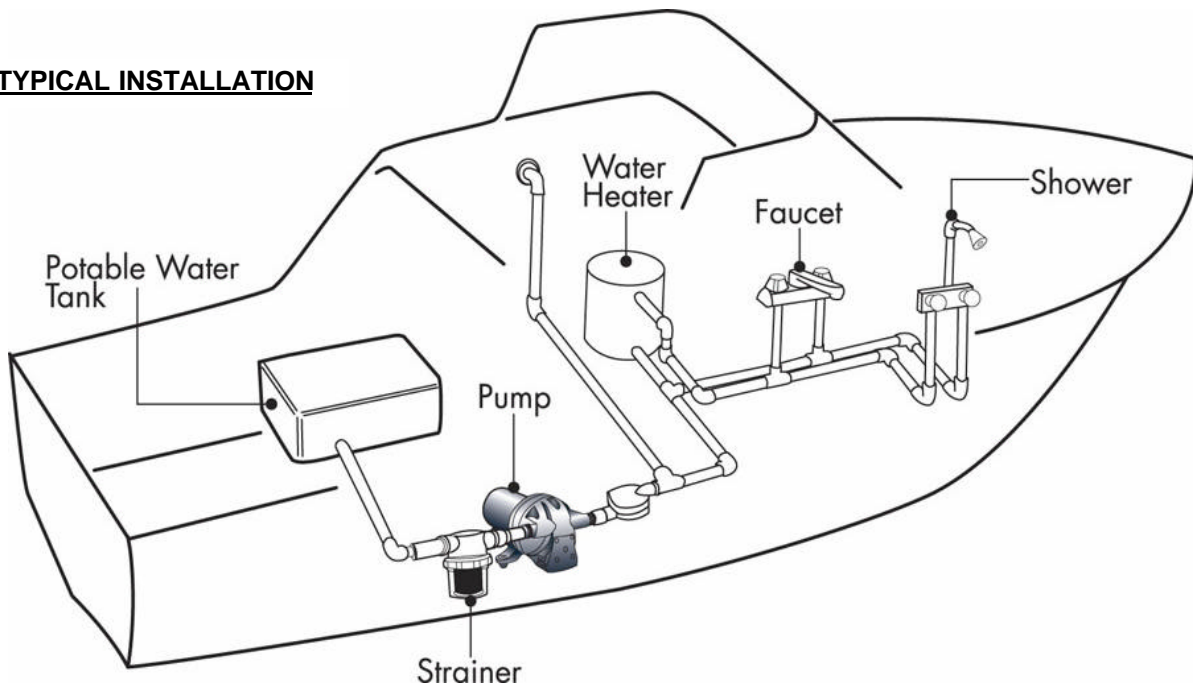

PLUMBING

Reducing unnecessary restrictions to the inlet and the outlet tubing will allow the pump to run freely, maximizing the Smart Sensor's performance, quietness and eliminate the possibility of cavitations (starving the pump).

- Installation of a 50 mesh strainer, such as SHURflo model 255 is recommended to prevent debris from entering the pump.
- SHURflo recommends at least 1ft. [.3 M] of ½" [13mm] I.D. flexible high pressure tubing to both ports. Ideally, the pumps ports and strainer **should not** be connected to plastic or rigid pipe. The pump's normal oscillation may transmit through rigid plumbing causing noise, and possibly loosen or crack components.
- Pump may flow better with 3/4" line feeding the pump.

WINTERIZING

NOTE: When used per the manufacturers recommendations **non-toxic antifreeze for potable water** is safe for use with SHURflo pumps. Make sure all components in the system are compatible. Hot water heaters and filters must be drained and by-passed when using potable water anti-freeze. Refer to the manufacturer and other equipment manufacturers for their specific winterizing & drainage instructions.



WARNING

Do not use Automotive Antifreeze to winterize potable water systems. Such solutions are highly toxic. Ingestion may cause serious injury or death. To properly drain the system, perform the following:

1. Drain the water tank. If the tank doesn't have a drain valve, open all faucets and let pump run until the tank is empty.
2. Open all the faucets (including the lowest valve or drain in the plumbing) and allow the pump to purge the water from the plumbing system, and then turn the pump OFF.
3. Using a pan to catch the remaining water, remove the plumbing at the pump's inlet/outlet ports. Turn the pump ON, allowing it to operate until the water is expelled. Turn OFF power to the pump once the plumbing is emptied. Do not reconnect pump plumbing. It is o.k. to lightly cover plumbing ends to prevent bugs from entering the system.

Make a note at tank filler as a reminder: "Plumbing is Disconnected".

4. All faucets should be left open to guard against any damage.
5. Potable water anti-freeze may be poured into drains to protect p-traps and waste system from freezing.
6. Fill system and **sanitize** before use in the spring.

SANITIZING

Sanitizing is recommended prior to storing and before using the water system after storage. Systems with new components, or ones subjected to contamination, should also be disinfected as follows:

NOTE: This procedure is in conformance with the approved procedures of ANSI A119.2.

1. Use one of the following methods to determine the amount of common household bleach needed to sanitize. A) 1-1/2 ounces of bleach per 10-gallon tank size. Example: 40 gallon tank = 4 x 1.5 = 6 ounces of bleach. B) Multiply "Liters of tank capacity" by 1.0; the result is the milliliters of bleach needed to sanitize the tank.
2. Mix the proper amount of bleach within a 1-gallon container of water.
3. Pour the solution (water bleach) into the tank and fill the tank with potable water. Rock vehicle back and forth to splash water on tank walls an top.
1. Open **all** faucets (Hot & Cold) allowing the water to run until the distinct odor of chlorine is detected.
2. The standard solution must have four (4) hours of contact time to disinfect completely. Doubling the concentration of bleach allows for contact time of one (1) hour.

When the contact time is completed, drain the tank. Refill with potable water and purge the plumbing of all sanitizing solution.

Troubleshooting

PUMP WILL NOT START/BLOWS CIRCUIT

- Electrical connections, fuse, breaker, main switch, and ground connection.
- Is the motor hot? Thermal protector may have triggered; will reset when cool.
- Is voltage present at the pump?
- Charging System for correct voltage (9-14) and good ground.
- For an open or grounded circuit or motor; improperly sized wire.
- For seized or locked diaphragm assembly (water frozen?)
- Is wire size too small? Minimum 14 AWG wire required.

WILL NOT PRIME/SPUTTERS: (No discharge / Motor runs)

- Is the strainer clogged with debris?
- Inlet cavitation from restrictions, small tubing? Outlet restrictions?
- Is there water in the tank, or air in the hot water heater?
- Is the inlet plumbing sucking air in air at connections (vacuum leak)?
- Is the inlet/outlet plumbing severely restricted or kinked?
- Proper voltage with the pump operating (9 - 14 volts).
- For debris in pump inlet/outlet valves or swollen/dry valves.
- Pump housing and drive assembly for cracks or loose screws.

PUMP WILL NOT SHUT OFF/RUNS WHEN FAUCET IS CLOSED

- Output side plumbing for leaks, and inspect for leaky valves or toilet.
- For air trapped in outlet side (water heater) or pump head.
- For bad transducer or transducer wire connections.
- For loose drive assembly or pump head screws.
- Are the valves held open by debris or swollen?

LEAKS FROM PUMP HEAD OR COVER

- For switch diah. leaking under cover.
- For picture diaphragm if water is present in the drive.
- Leaks from fitting? Check o-ring in groove? o-ring lubricated properly?

NOISY OR ROUGH OPERATION

- For plumbing which may have vibrated loose.
- Is pump plumbed with rigid pipe causing noise to transmit?
- Does the mounting surface amplify noise?
- For mounting feet that are loose or compressed too tight.
- For loose pump head to motor screws.
- For air in system.
- The motor with pump head removed. Is noise from motor when it runs alone?

2

1

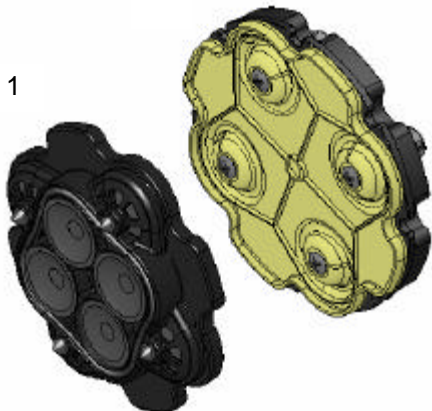

SERVICE KITS

1	Valve Assembly	94-669-01
2	Drive Assembly	94-670-00

STRAINERS AVAILABLE:

Number	Components	Part Number
1	1/2 NPS-M x 1/2 NPS-F	255-213
2	1/2 Barb Straight x 1/2 NPS-F	255-223
3	1/2 Barb Straight x 1/2 NPT Hex Wing Nut	255-225
4	1/2 NPS-M x 1/2 NPT Hex Wing Nut	255-215



NEW HEX-WING FITTINGS AVAILABLE

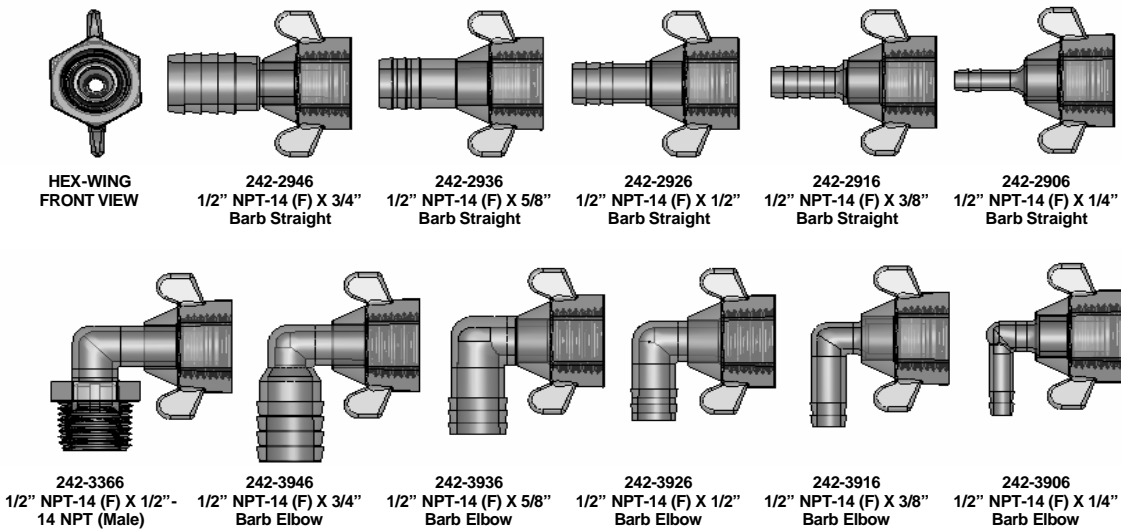

LIMITED WARRANTY

SHURflo warrants its 4901 Fresh Water pumps to be free from material and workmanship defects under normal use and service for a period of three (3) years from the date of manufacture indicated on the motor nameplate. The limited warranty will not apply to pumps that were improperly installed, misapplied, or are incompatible with components not manufactured by SHURflo. Pump failure due to foreign debris is not covered under the terms of this limited warranty. SHURflo will not warrant any pump that is physically damaged, or altered outside the SHURflo factory. Warranty claims may be resolved by an authorized dealer service center, or by a SHURflo service center. Returns are to be shipped with charges pre-paid. Package all returns carefully. SHURflo will not be responsible for freight damage incurred during shipping to a service center. For complete Limited Warranty details, please contact SHURflo.



*ISO Registered Facility

SHURflo reserves the right to update specifications, prices, or make substitutions.

SHURflo, LLC*
 5900A Katella Ave.
 Cypress, Ca. 90630
 Phone: 800 854 3218
 Fax: 562 795 7554
 Shipping: 5900C Katella Ave.
 Cypress, Ca. 90630

SHURflo East
 52748 Park Six Court
 Elkhart, IN 46514-5427
 Phone: 800 854 3218
 Fax: 574 264 2169
 Http://www.shurflo.com
 © 2001

SHURflo Ltd.*
 Unit 5, Sterling Park
 Gatwick Road, Crawley
 West Sussex, RH10 9QT
 United Kingdom
 Phone: 0044 (0) 1293 424 000
 Fax: 0044 (0) 1293 421 880