



INSTALLATION AND OPERATION MANUAL

The Blaster Pump delivers water on demand. With the spray nozzle off (output side closed) the pump will turn off. As the nozzle is opened, the pressure within the hose (output side) drops. Once the pressure drops below a predetermined point, the pumps pressure switch closes and the pump operates. With the nozzle set at a fine mist the pump will cycle, as it is able to pressurize the hose faster than water being released. If the spray nozzle is held wide open the pump may operate continually. The pump may momentarily operate even after the nozzle is closed, as it pressurizes the hose. Once the pressure setting is reached the switch opens and the pump stops.

DUTY CYCLE

Wash-down pumps are rated for intermittent duty, as they operate at higher than average pressures. Operating a pump continuously for more than twenty (20) minutes, within an hour period, is not recommended. Actual duty cycle is determined by amp draw, temperature, and rate of cycling.

NOTE: Rapid cycling should be minimized to ensure long life. Rapid cycling is defined as ON/OFF within two seconds. For best results, use the 8 oz SHURflo accumulator tank model # 182 series.

TYPICAL INSTALLATION

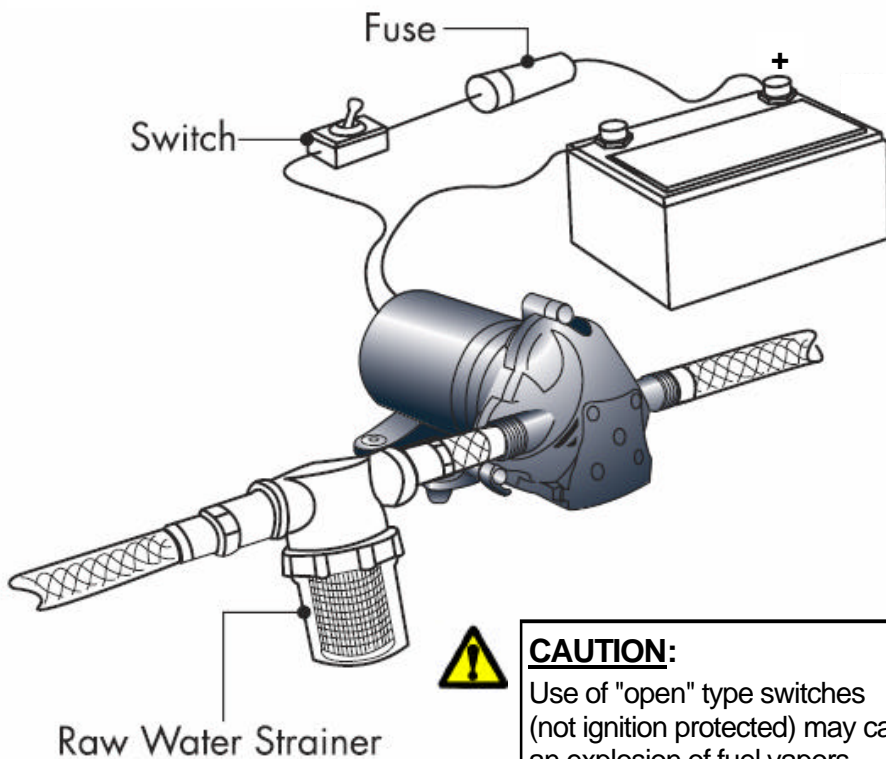

CAUTION:

Use of "open" type switches (not ignition protected) may cause an explosion of fuel vapors.

ELECTRICAL

- The pump should be on a dedicated (individual) circuit protected by the specified fuse indicated on the motor label.
- A U/L approved marine duty (ignition protected) switch rated at or above 15 amps is recommended, and must interrupt current flow on the positive (+ red) lead.
- Wire size (gauge/mm²) is based on the distance from the power source to the pump. The minimum recommended wire size is #14 gauge [2.5mm²]. For lengths of 20-50 ft. [6-15M] use #12 gauge [4mm²]. The pump must be grounded to a "known ground" (battery). The ground wire must be the same size as the positive wire.

MOUNTING

- Consider a **dry** location that allows easy access if maintenance is required. The pump should not be located in an area of less than one cubic foot unless adequate ventilation is provided. Excessive heat may trigger the integral thermal breaker and interrupt operation. When the temperature drops the breaker will automatically reset and start operation.
- Mount higher than the outside water (sea) level. The pump is capable of a 6 ft. [2M] vertical prime above the outside water level. The pump can be mounted in any position. If mounting the pump vertically, the pump head should be in the down position.

CAUTION: *Do not* drive screws through the vessel's hull. Use #8 stainless steel hardware to fasten the pump. Choose a **solid** surface (bulkhead or stringer) that will not amplify pump sound. The mounting feet are intended to isolate the pump from the mounting surface; over-tightening, flattening, or oversized screws will reduce the mounting pads ability to isolate vibration and noise.

PLUMBING

- SHURflo swivel/hex barb fittings provide easy removal if maintenance or access required. The fittings are designed with a "taper-seal", creating a water tight connection when **hand-tightened**. Always secure barb tubing connections with properly sized stainless steel clamps to prevent leaks.
- Avoid any sharp radius in tubing that may kink over time. Route tubing away from any heat (exhaust manifolds etc.) and fasten securely.
- Inlet tubing (½" I.D. min.) from the seacock valve to the pump should be rated for vacuum. If rigid pipe is utilized, SHURflo recommends that the pump inlet port be plumbed with 1 ft. [.3M] of flexible tubing. Standard garden hose is not suitable as inlet tubing as it may collapse under vacuum, reducing water flow.
- The pump outlet port **should not** be connected to rigid (plastic) pipe. Normal oscillation of the pump may transmit through rigid plumbing causing noise and possibly loosen or crack components. A 1ft. [.3M] length of flexible high-pressure tubing is suggested. Optional SHURflo silencing kits are available for connecting to rigid tubing.

NOTES:

- To prevent cavitation, through hull fittings should be located at least 12 in. off the centerline of the water pick-up for the motor.
- The through hull fitting must have a seacock valve to shut-off in case of an emergency.
- Always use high quality non-corrosive fittings, valves and hardware to assure long-term reliability.
- Properly seal all pipe threads before the strainer to prevent unforeseen leaks. **Never** use Teflon tape or sealing compounds on SHURflo pump threads or fittings. Sealer may enter the pump causing a failure not covered under warranty.

STRAINER / FILTRATION

Installation of a 50-mesh minimum strainer, such as SHURflo 253 series, is recommended to prevent debris from entering the pump. SHURflo recommends at least 1ft. (.3 M) of 1/2" or 3/4" (13mm) I.D. flexible high-pressure tubing on both ports. Ideally, the pump ports and strainers should not be connected to plastic or rigid pipe. The pump's normal oscillation may transmit through rigid plumbing causing noise, and possible loosen or cracking components.

CAUTION:

The strainer **must** be mounted above the outside water line to prevent water from siphoning during cleaning. Mount the strainer where it can be inspected and cleaned easily without closing the seacock valve.

WINTERIZING

If water is allowed to freeze in the system, serious damage to the plumbing and pump may occur. Failures of this type will void the warranty. The best guarantee against damage is to completely drain the wash down system. To properly drain the system perform the following:

- Drain the water tank. If the tank doesn't have a drain valve, open all faucets and let pump run until tank is empty.
- Open all the faucets (including the lowest valve or drain in the plumbing) and allow the pump to purge the water from the plumbing system, and then turn the pump OFF.
- All faucets should be left open to guard against any damage.
- Potable water anti-freeze may be poured into drains to protect p-traps and waste system from freezing.
- Fill system and sanitized before re-use.

PUMP WILL NOT START/ BLOWS CIRCUIT:

- ✓ Is the motor hot? Thermal breaker may have triggered; it will reset when cool.
- ✓ Electrical connections, fuse, main switch, and ground. (corrosion)
- ✓ Is voltage present at the switch? Bypass the pressure switch. Does the pump operate?
- ✓ Charging System for voltage ($\pm 10\%$) and good ground.
- ✓ For improper fuse rating or wire size.
- ✓ For an open or grounded circuit, or motor.
- ✓ For seized or locked drive/diaphragm assembly.

WILL NOT PRIME/SPUTTERS: (No discharge/Motor runs)

- ✓ Is the strainer clogged with debris?
- ✓ Is there debris in the through hull fitting?
- ✓ Is the inlet plumbing sucking in air at tubing connections (vacuum leak)?
- ✓ Is inlet/outlet plumbing severely restricted or kinked?
- ✓ Proper voltage with the pump operating ($\pm 10\%$).
- ✓ For debris in pump inlet/outlet valves or swollen/dry valves.
- ✓ Pump housing for cracks or loose drive assembly screws.

PUMP WILL NOT SHUT-OFF / RUNS WHEN NOZZLE IS CLOSED:

- ✓ Output side (pressure) plumbing for leaks.
- ✓ For air trapped in outlet side or pump head.
- ✓ For correct voltage to pump ($\pm 10\%$).
- ✓ For loose drive assembly or pump head screws.
- ✓ Is the internal check valve held open? Are the valves swollen or held open by debris?
- ✓ Pressure switch operation/adjustment incorrect.

NOISY OR ROUGH OPERATION:

- ✓ For plumbing which may have vibrated loose.
- ✓ Is the pump plumbed with rigid pipe causing noise to transmit?
- ✓ Does the mounting surface multiply noise (flexible)?
- ✓ For mounting feet that are loose or compressed too tight.
- ✓ For loose pump head or drive screws.
- ✓ The motor with pump head removed (3 long screws). Is noise from motor or pump head?

LEAKS FROM PUMP HEAD OR SWITCH:

- ✓ For loose screws at switch or pump head.
- ✓ Switch diaphragm ruptured or pinched.
- ✓ For punctured diaphragm if water is present in drive assembly.
- ✓ Check for damaged pump head (cracked).

GENERAL SAFETY PRECAUTIONS

- When the vessel is not in use, the main power switch should be off and seacock valves should be CLOSED. However, if left afloat, the bilge pump should still have power.
- Never operate the engine or electrical equipment if fuel vapor is detected. Locate the source and vent properly.
- Electrical connections should be soldered and insulated to prevent shorts and corrosion. Wiring should be routed away from areas prone to water, heat and excess moisture.

SERVICE KITS

- 1 Pressure Switch 94-706-00
- 2 Upper Housing 94-706-01
- 3 Valve Housing 94-706-02
- 4 Drive Assembly 94-706-06
- 5 Motor 12V 11-173-06

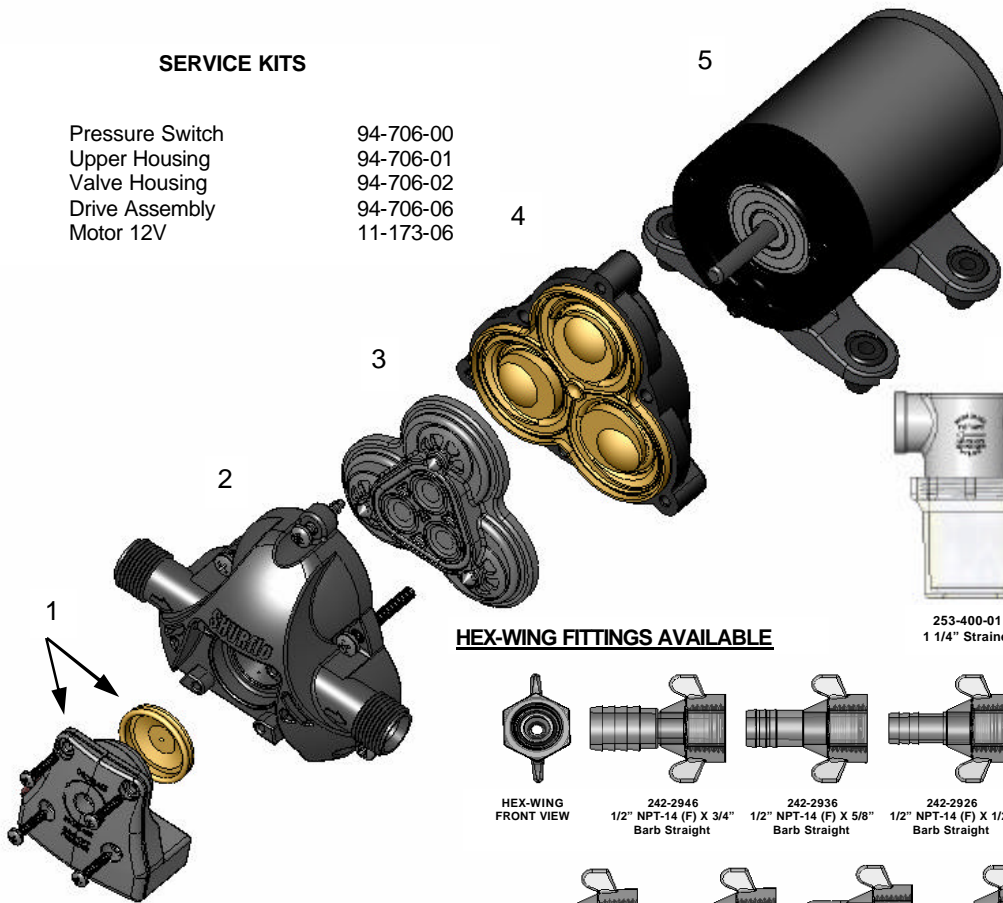

Raw Water Strainers Available

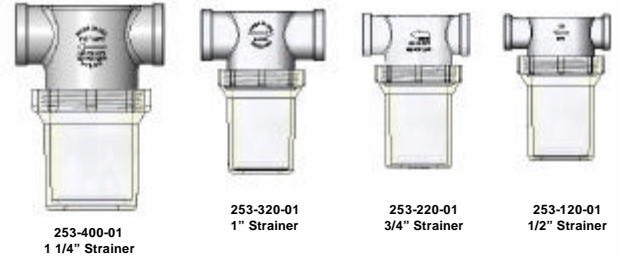

HEX-WING FITTINGS AVAILABLE

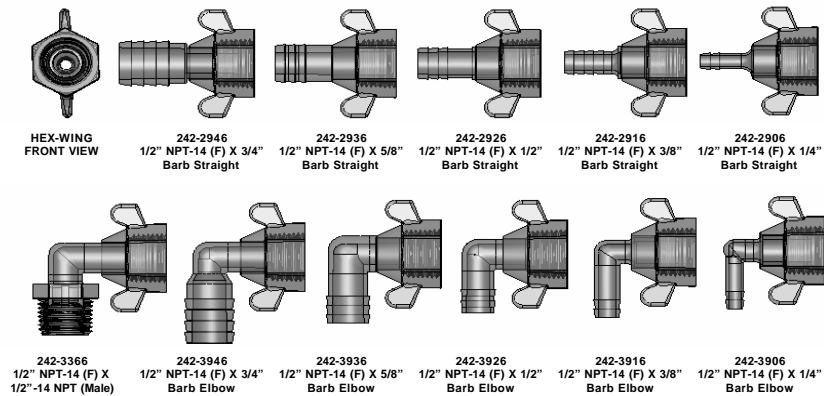

LIMITED WARRANTY

SHURflo warrants The Blaster series pump to be free from material and workmanship defects under normal use and service for a period of (1) one year from the date of purchase. In the absence of proof of purchase the warranty is (1) one year from the date of manufacture indicated on the motor nameplate, not to exceed one year in any event. Pumps used in commercial applications are warranted for three (3) months from date of purchase only (proof required). The limited warranty will not apply to pumps that were improperly installed, misapplied, or incompatible with components not manufactured by SHURflo. Pump failure due to foreign debris is not covered under the terms of this limited warranty. SHURflo will not warrant any pump that is physically damaged, or altered outside the SHURflo factory. Warranty claims may be resolved by an authorized dealer service center, or by a SHURflo service center. All returns are to be shipped with charges pre-paid. Package all returns carefully. SHURflo will not be responsible for freight damage incurred during shipping to a service center. SHURflo's obligation under this warranty policy is limited to the repair or replacement of the pump. Pumps found not defective (under the terms of this limited warranty) are subject to charges to be paid by the returnee for the testing and packaging of "tested good" units. Warranty returns will be shipped on a freight allowed basis. SHURflo reserves the right to choose the method of transportation. SHURflo is not responsible nor will it reimburse for labor necessary to remove and reinstall a pump, if found defective. This warranty is only a representation of the complete Marine Products Limited Warranty outlined by Service Bulletin #1050.



*ISO Registered Facility

SHURflo reserves the right to update specifications, prices, or make substitutions.



SHURflo, LLC*
 5900A Katella Ave.
 Cypress, Ca. 90630
 Phone: 800 854 3218
 Fax: 562 795 7554
 Shipping: 5900C Katella Ave.
 Cypress, Ca. 90630

SHURflo East
 52748 Park Six Court
 Elkhart, IN 46514-5427
 Phone: 800 854 3218
 Fax: 574 264 2169
 Http://www.shurflo.com
 © 2001

SHURflo Ltd.*
 Unit 5, Sterling Park
 Gatwick Road, Crawley
 West Sussex, RH10 9QT
 United Kingdom
 Phone: 0044 (0) 1293 424 000
 Fax: 0044 (0) 1293 421 880