



EXTREME PRO BLASTER™ WASH-DOWN PUMP **INSTALLATION AND OPERATION MANUAL**

The Extreme Pro Blaster delivers water on demand. With the spray nozzle off (output side closed) the pump will turn off. As the nozzle is opened, the pressure within the hose (output side) drops. Once the pressure drops below a predetermined point, the pumps pressure switch closes and the pump operates. With the nozzle set at a fine mist the pump will cycle, as it is able to pressurize the hose faster than water being released. If the spray nozzle is held wide open the pump may operate continually. The pump may momentarily operate even after the nozzle is closed, as it pressurizes the hose. Once the pressure setting is reached the switch opens and the pump stops.

DUTY CYCLE

Wash-down pumps are rated for intermittent duty, as they operate at higher than average pressures. Operating a pump continuously for more than twenty (20) minutes, within an hour period, is not recommended. Actual duty cycle is determined by amp draw, temperature, and rate of cycling.

NOTE: Rapid cycling should be minimized to ensure long life. Rapid cycling is defined as ON/OFF within two seconds. For best results, use the 2 gal SHURflo stainless steel accumulator tank model # 3400 series.

MOUNTING

- Consider a **dry** location that allows easy access if maintenance is required. The pump should not be located in an area of less than one cubic foot unless adequate ventilation is provided. Excessive heat may trigger the integral thermal breaker and interrupt operation. When the temperature drops the breaker will automatically reset and start operation.
- Mount higher than the outside water (sea) level. The pump is capable of a 6 ft. [2M] vertical prime above the outside water level. The pump can be mounted in any position. If mounting the pump vertically, the pump head should be in the down position.

CAUTION: *Do not* drive screws through the vessel's hull.

Use #8 stainless steel hardware to fasten the pump. Choose a **solid** surface (bulkhead or stringer) that will not amplify pump sound. The mounting feet are intended to isolate the pump from the mounting surface; over-tightening, flattening, or oversized screws will reduce the mounting pads ability to isolate vibration and noise.

ELECTRICAL

- The pump should be on a dedicated (individual) circuit protected by the specified fuse indicated on the motor label.
- A U/L approved marine duty (ignition protected) switch rated at or above 15 amps is recommended, and must interrupt current flow on the positive (+ red) lead.

⚠ CAUTION:

Use of "open" type switches (not ignition protected) may cause an explosion of fuel vapors.

- Wire size (gauge/mm²) is based on the distance from the power source to the pump. The minimum recommended wire size is #14 gauge [2.5mm²]. For lengths of 20-50 ft. [6-15M] use #12 gauge [4mm²]. The pump must be grounded to a "known ground" (battery). The ground wire must be the same size as the positive wire.

PLUMBING

- SHURflo quick connect fittings provide easy installation and removal if required. The fittings are designed with dual o-rings, creating a seal when snapped into place.
- Avoid any sharp radius in tubing that may kink over time. Route tubing away from any heat (exhaust manifolds etc.) and fasten securely.
- Inlet tubing (½" I.D. min.) from the seacock valve to the pump should be rated for vacuum. If rigid pipe is utilized, SHURflo recommends that the pump inlet port be plumbed with 1 ft. [.3M] of flexible tubing. Standard garden hose is not suitable as inlet tubing as it may collapse under vacuum, reducing water flow.
- The pump outlet port **should not** be connected to rigid (plastic) pipe. Normal oscillation of the pump may transmit through rigid plumbing causing noise and possibly loosen or crack components. A 1ft. [.3M] length of flexible high-pressure tubing is suggested.

NOTES:

- To prevent cavitation, through hull fittings should be located at least 12 in. off the centerline of the water pick-up for the motor.
- The through hull fitting must have a seacock valve to shut-off in case of an emergency.
- Always use high quality non-corrosive fittings, valves and hardware to assure long-term reliability.
- Properly seal all pipe threads before the strainer to prevent unforeseen leaks. **Never** use Teflon tape or sealing compounds on SHURflo pump threads or fittings. Sealer may enter the pump causing a failure not covered under warranty.

STRAINER / FILTRATION

Installation of a 40-mesh minimum strainer, such as SHURflo series 253 or 254, is recommended to prevent debris from entering the pump. SHURflo recommends at least 1ft. (.3 M) of 1/2" or 3/4" (13mm) I.D. flexible high-pressure tubing on both ports. Ideally, the pump ports and strainers should not be connected to plastic or rigid pipe. The pump's normal oscillation may transmit through rigid plumbing causing noise, and possible loosen or cracking components. SHURflo quick-connect fittings provide easy installation and removal if required.

CAUTION:

The strainer **must** be mounted above the outside water line to prevent water from siphoning during cleaning. Mount the strainer where it can be inspected and cleaned easily without closing the seacock valve.

WINTERIZING

If water is allowed to freeze in the system, serious damage to the plumbing and pump may occur.

Failures of this type will void the warranty. The best guarantee against damage is to completely drain the wash down system. To properly drain the system perform the following:

- Drain the water tank. If the tank doesn't have a drain valve, open all faucets and let pump run until tank is empty.
- Open all the faucets (including the lowest valve or drain in the plumbing) and allow the pump to purge the water from the plumbing system, and then turn the pump OFF.
- All faucets should be left open to guard against any damage.
- Potable water anti-freeze may be poured into drains to protect p-traps and waste system from freezing.
- Fill system and sanitized before re-use.

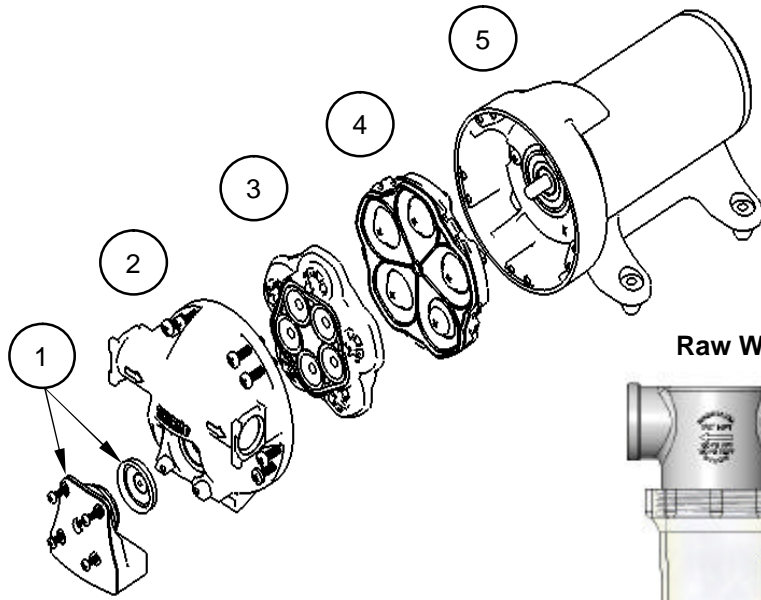

SERVICE KITS

#	Component	Part Kit #:
1	Pressure Switch	94-069-00
2	Upper Housing	94-670-02
3	Valve Assembly	94-030-01
4	Drive Assembly	94-030-02
5	Motor 12V DC	77-007-17
5	Motor 24V DC	77-009-17
5	Motor 32V DC	77-010-17

Raw Water Strainers Available (Sold Separately)

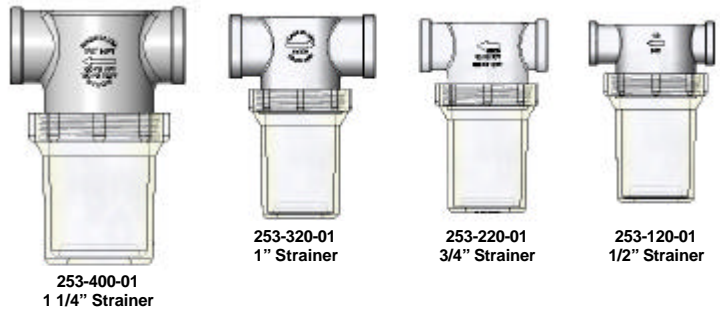

254 STRAINERS FITTING KITS (Sold Separately)

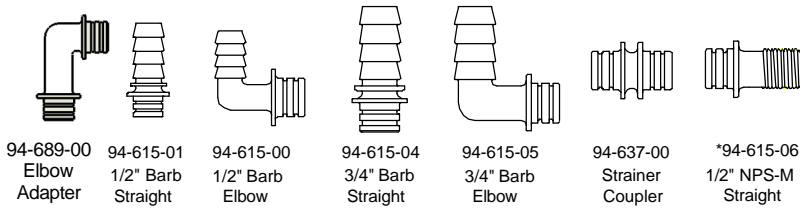

94-689-00 Elbow Adapter
 94-615-01 1/2" Barb Straight
 94-615-00 1/2" Barb Elbow
 94-615-04 3/4" Barb Straight
 94-615-05 3/4" Barb Elbow
 94-637-00 Strainer Coupler
 *94-615-06 1/2" NPS-M Straight

* Included with Aftermarket Extreme Pro Blaster pump kits.

MODEL 254 STRAINER (Sold Separately)

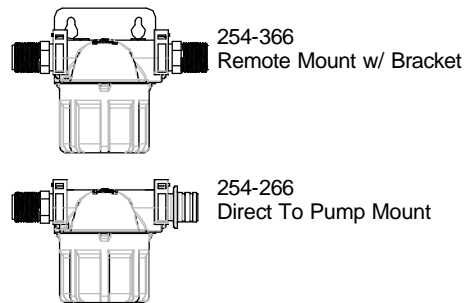

FITTINGS INSTALLATION INSTRUCTIONS

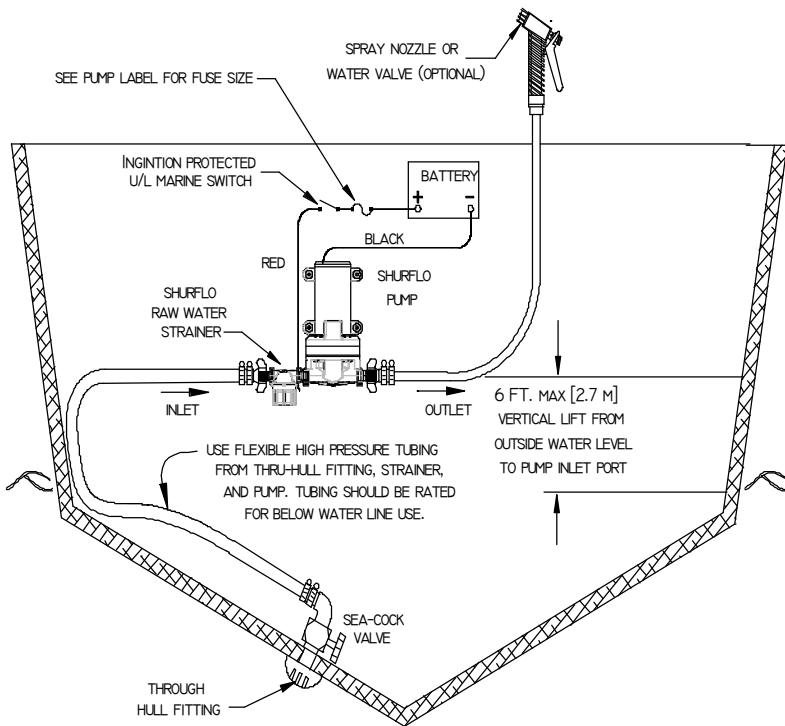

Pump clip original stage.

Step #1: Place your thumb at the edge of the clip as shown.

Step #2: Using your thumb, pry up edge of lock clip over lock tab. (as shown)

Step #3: Insert strainer or fitting into quick connect port, push all the way until stops.

Step #4: Place your thumb on top of the clip as shown.

Step #5: Snap lock clip over fitting and lock. Pull fitting to make sure is locked in to place.

GENERAL SAFETY PRECAUTIONS

- When the vessel is not in use, the main power switch should be off and seacock valves should be **CLOSED**. However, if left afloat, the bilge pump should still have power.
- Never operate the engine or electrical equipment if fuel vapor is detected. Locate the source and vent properly.
- Electrical connections should be soldered and insulated to prevent shorts and corrosion. Wiring should be routed away from areas prone to water, heat and excess moisture.

LIMITED WARRANTY

SHURflo warrants The Extreme Pro Blaster series pump to be free from material and workmanship defects under normal use and service for a period of (3) three years from the date of purchase. In the absence of proof of purchase the warranty is (3) three years from the date of manufacture indicated on the motor nameplate, not to exceed three years in any event. Pumps used in commercial applications are warranted for six months from date of purchase only (proof required). The limited warranty will not apply to pumps that were improperly installed, misapplied, or incompatible with components not manufactured by SHURflo. Pump failure due to foreign debris is not covered under the terms of this limited warranty. SHURflo will not warrant any pump that is physically damaged, or altered outside the SHURflo factory. Warranty claims may be resolved by an authorized dealer service center, or by a SHURflo service center. All returns are to be shipped with charges pre-paid. Package all returns carefully. SHURflo will not be responsible for freight damage incurred during shipping to a service center. SHURflo's obligation under this warranty policy is limited to the repair or replacement of the pump. Pumps found not defective (under the terms of this limited warranty) are subject to charges to be paid by the returnee for the testing and packaging of "tested good" units. Warranty returns will be shipped on a freight allowed basis. SHURflo reserves the right to choose the method of transportation. SHURflo is not responsible nor will it reimburse for labor necessary to remove and reinstall a pump, if found defective. This warranty is only a representation of the complete Marine Products Limited Warranty outlined by Service Bulletin #1050.



- ES** Favor de referirse a www.shurflo.com para instrucciones de la instalación del producto y su operación, disponible en varios idiomas.
- DE** Mehrsprachige Hinweise zu Installation und Betrieb des Produktes finden Sie unter www.shurflo.com
- IT** Fare riferimento al sito www.shurflo.com per manuali multilingue di installazione ed utilizzo prodotti.
- FR** Veuillez vous référer au site www.shurflo.com pour l'installation produit multilingue ainsi que pour le mode d'emploi.
- UK** Please refer to www.shurflo.com for multi-lingual product installation and operating instructions'

SHURflo reserves the right to update specifications, prices, or make substitutions.



SHURflo, LLC Headquarters

5900 Katella Avenue
Cypress, California 90630
Phone (562) 795-5200 • Toll Free (800) 854-3218
Fax (562) 795-7564

SHURflo, LLC East

52748 Park Six Court
Elkhart, Indiana 46514-5427
Phone (562) 795-5200 • Toll Free (800) 854-3218
Fax (574) 264-2169

SHURflo Europe, Middle East, Africa

Pentair Water Belgium bvba,
Industriepark Wolfstee, Toekomstlaan 30
B-2200 Herentals, Belgium
Phone +32-14-283500 • Fax +32-14-283505