

SHURflo[®] Marine Grade Faucets

INSTALLATION INSTRUCTIONS

OEM Version

Attention Manufacturers:
Please include this Installation
Instruction sheet with your Owner's
Documentation.

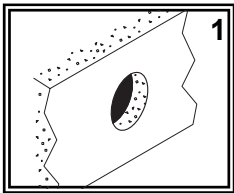

- (1) Check desired position to ensure adequate space under the deck or inside the wall for the recessed cup plus the item be installed inside the cup. Drill 2 ⁷/₈" to 3" hole in the desired location.

- (2) Place the recessed cup and lid into the hole.

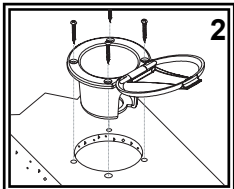

Wall Mount—Place into the hole with the hinge pointing DOWN. This will allow the lid to fall out of the way of the item installed inside the cup when in use. Secure recessed cup and lid using the provided four (4) screws.

Deck Mount—Place into the hole with the hinge pointing in the desired direction for the lid to easily lay open when in use. Secure recessed cup and lid using the provided four (4) screws.

Add Shut-Off Valve (136-0204-CP) to the Recessed Cup



Add Hand Held Sprayer (134-0011-WH) to the Recessed Cup



Parts

- 1) Recessed Cup
- 2) Lid
- 3) Mounting Screws (4x)

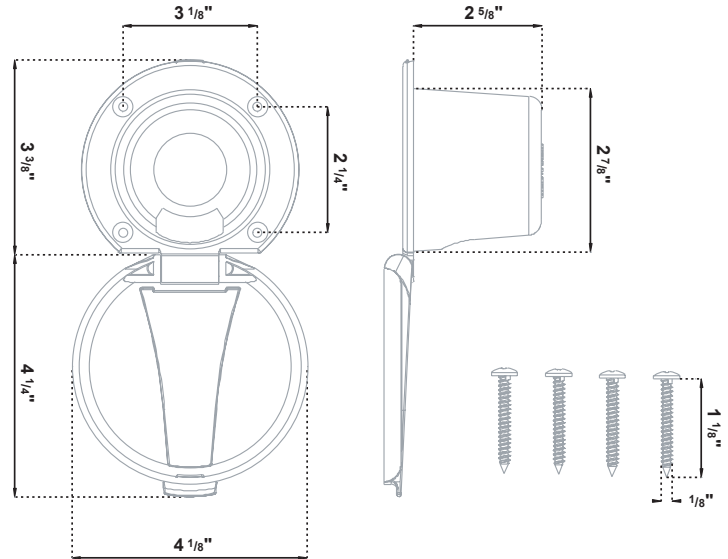
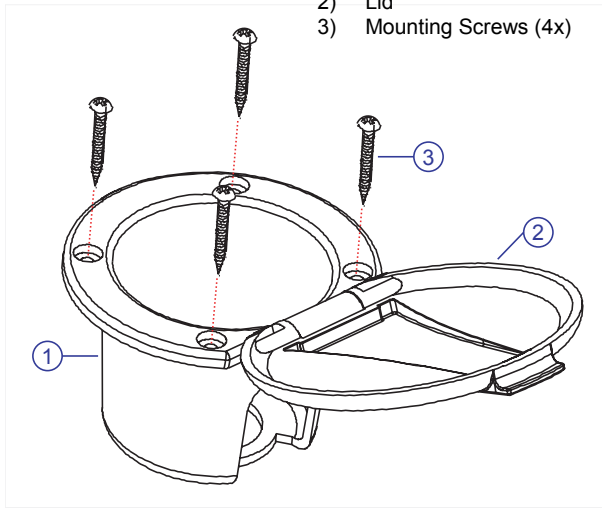

PROPER FINISH CARE:

Your new accessory is protected by a clear-coat. To clean it, you only need to wipe it with a damp, soft cloth. **NEVER** use any abrasive cleaners, steel wool, or chemicals, as they will harm the finish and void your warranty. If the accessory will be installed in a salt-air environment (boat exterior), regular cleaning with gentle soap and carnauba wax will prolong the life of the finish.

LIMITED WARRANTY

SHURflo Marine Grade Faucets & Accessories are guaranteed to be free from material and workmanship defects under normal use and service for a period of three (3) years from the date of manufactured vessel for all indoor applications and two (2) years from the date of manufactured vessel for all outdoor applications. This limited warranty will not apply to faucets or accessories that were improperly installed, misapplied, or incompatible with components not manufactured by SHURflo. Faucet failure due to foreign debris is not covered under the terms of this limited warranty. SHURflo will not warrant any faucet that is physically damaged, or altered outside the SHURflo factory. Warranty claims may be resolved by a SHURflo service center. All returns are to be shipped with charges pre-paid. Package all returns carefully. SHURflo will not be responsible for freight damage incurred during shipping to a service center. SHURflo's obligation under this warranty policy is limited to the repair or replacement of the faucets & accessories. Faucets or accessories found not defective (under the terms of this limited warranty) are subject to charges to be paid by the returnee for the testing and packaging of "tested good" units. Warranty returns will be shipped on a freight allowed basis. SHURflo reserves the right to choose the method of transportation. SHURflo is not responsible nor will it reimburse for labor necessary to remove and reinstall a faucet or accessory, if found defective. This warranty is only a representation of the complete Marine Products Limited Warranty outlined by Service Bulletin #1050.

★SHURflo reserves the right to update specifications, prices, or make substitutions.



SHURflo*
5900-A Katella Ave.
Cypress, CA 90630
(562) 795-5200 (800) 854-3218
FAX (562) 795-7564
Shipping: 5900-C Katella Ave.
Cypress, CA 90630

SHURflo East
52748 Park Six Court
Elkhart, IN 46514-5427
(574) 262-0478 (800) 762-8094
FAX (574) 264-2169
<http://www.shurflo.com>

SHURflo Ltd.*
Unit 5 Sterling Park
Gatwick Road, Crawley
West Sussex, RH10 2QT
United Kingdom
+44 1293 424000
FAX +44 1293 421880

