

SHURflo[®] Marine Grade Faucets

INSTALLATION INSTRUCTIONS

OEM Version

Attention Manufacturers:
Please include this Installation
Instruction sheet with your Owner's
Documentation.

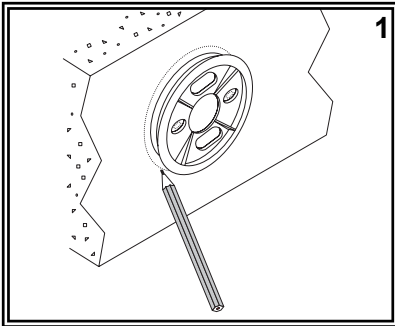

Towel Ring / Robe Hook / Cup Holder / Soap Dish / Single Post TP Holder

- 1) Hold item on the wall where desired. With a pencil, lightly trace a circle completely around the base of the item. Remove the item. Hold a mounting bracket directly in the center of the outline (see figure 1). Trace a circle around the mounting bracket and the two mounting screw holes.
- 2) Mount the bracket as shown (see figure 2). For mounting into wood, fiberglass, or other solid surface, drill a 1/8" starter hole and attach the bracket to the wall.
- 3) Secure the item to the bracket (see figure 3) with the set screw pointing down. Tighten the set screw.

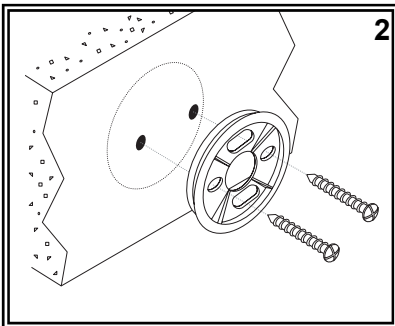

18" Towel Bar / 24" Towel Bar / Double Post TP Holder

- 1) Hold one of the posts on the wall where desired. With a pencil, lightly trace a circle completely around the base of the post. Remove the post. Hold a mounting bracket directly in the center of the outline (see figure 1). Trace a circle around the mounting bracket and the two mounting screw holes.
- 2) Mount the bracket as shown (see figure 2). For mounting into wood, fiberglass, or other solid surface, drill a 1/8" starter hole and attach the bracket to the wall.
- 3) Secure the post to the bracket (see figure 3) with the set screw pointing down. Tighten the set screw.
- 4) For the other end, merely set the bar or roller into the mounted post and hold the other post at the correct spot. NOTE: Mount the second post "in" tightly so that there is no side to side movement of the bar. USE A BUBBLE LEVEL TO INSURE THAT THE BAR IS LEVEL. Trace a circle around the second post (see figure 1) and mount.

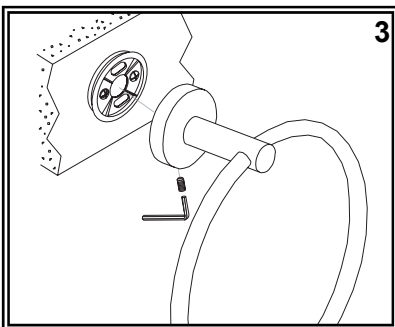

Parts

- 1) Mounting Bracket
- 2) Mounting Screws
- 3) Bolt
- 4) Base
- 5) Set Screw
- 6) Body
- 7) Set Screw
- 8) Sleeve
- 9) Bar
- 10) Lid

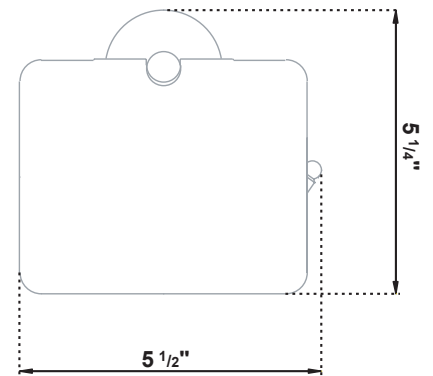
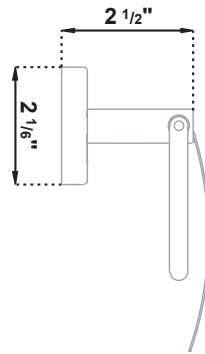
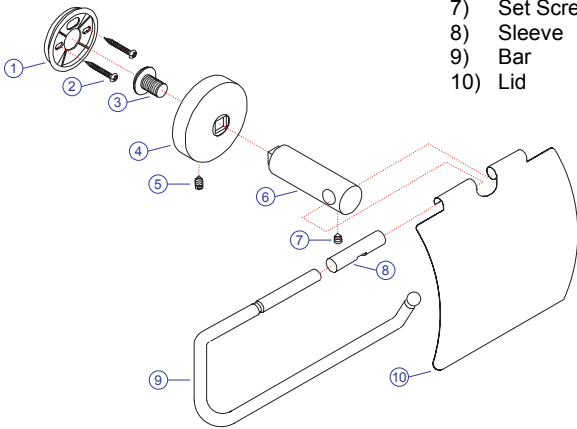

PROPER FINISH CARE:

Your new accessory is protected by a clear-coat. To clean it, you only need to wipe it with a damp, soft cloth. **NEVER** use any abrasive cleaners, steel wool, or chemicals, as they will harm the finish and void your warranty. If the accessory will be installed in a salt-air environment (boat exterior), regular cleaning with gentle soap and carnauba wax will prolong the life of the finish.

LIMITED WARRANTY

SHURflo Marine Grade Faucets & Accessories are guaranteed to be free from material and workmanship defects under normal use and service for a period of three (3) years from the date of manufactured vessel for all indoor applications and two (2) years from the date of manufactured vessel for all outdoor applications. This limited warranty will not apply to faucets or accessories that were improperly installed, misapplied, or incompatible with components not manufactured by SHURflo. Faucet failure due to foreign debris is not covered under this limited warranty. SHURflo will not warrant any faucet that is physically damaged, or altered outside the SHURflo factory. Warranty claims may be resolved by a SHURflo service center. All returns are to be shipped with charges pre-paid. Package all returns carefully. SHURflo will not be responsible for freight damage incurred during shipping to a service center. SHURflo's obligation under this warranty policy is limited to the repair or replacement of the faucets & accessories. Faucets or accessories found not defective (under the terms of this limited warranty) are subject to charges to be paid by the returnee for the testing and packaging of "tested good" units. Warranty returns will be shipped on a freight allowed basis. SHURflo reserves the right to choose the method of transportation. SHURflo is not responsible nor will it reimburse for labor necessary to remove and reinstall a faucet or accessory, if found defective. This warranty is only a representation of the complete Marine Products Limited Warranty outlined by Service Bulletin #1050.

★SHURflo reserves the right to update specifications, prices, or make substitutions.



SHURflo*
5900-A Katella Ave.
Cypress, CA 90630
(562) 795-5200 (800) 854-3218
FAX (562) 795-7564
Shipping: 5900-C Katella Ave.
Cypress, CA 90630

SHURflo East
52748 Park Six Court
Elkhart, IN 46514-5427
(574) 262-0478 (800) 762-8094
FAX (574) 264-2169
<http://www.shurflo.com>

SHURflo Ltd.*
Unit 5 Sterling Park
Gatwick Road, Crawley
West Sussex, RH10 2QT
United Kingdom
+44 1293 424000
FAX +44 1293 421880

