



Model 5902 Extreme Series Pump/Accumulator Combination INSTALLATION AND OPERATION MANUAL

The most advanced system available. This fully-automatic potable and raw water system delivers smooth, consistent flow at all ranges of operation, while drawing low current. The balanced diaphragm design incorporates two precision ball bearings for long life. SHURflo pumps are 100% tested before leaving the factory.



CAUTION

To prevent possible serious or fatal injury.
Do not exceed 50 PSI [3.4 bar] working pressure on the tank.

CAUTION

GENERAL SAFETY PRECAUTIONS

- If fuel vapor is detected, never operate the engine or electrical equipment until the source is located and/or properly vented.

MOUNTING

- All tanks should be securely mounted horizontally to a solid foundation with the pre-charge valve “out” for maintenance and convenience. Pump can be mounted on top of tank or beside it.
- The unit should be located in an area that is dry and provides adequate ventilation. If mounted within an enclosure, a provision to cool the motor may be necessary.
- System is not rated for below waterline installation. The strainer and pump **must** be mounted above the outside water line.
- The pump is capable of a 6 ft. [2M] vertical prime.

PLUMBING:

- SHURflo recommends that the pump inlet and outlet ports be plumbed with at least 1 ft. [.3M] of flexible tubing. Inlet tubing 1/2" I.D. min [mm] from the tank to the pump should be rated for vacuum. Standard garden hose is not suitable as inlet tubing will collapse under vacuum, reducing water flow and possibly damaging the pump. The system outlet port **should not** be connected to rigid (plastic) pipe. Normal oscillation of the system may transmit through rigid plumbing causing noise and possibly loosen or crack components.
- Avoid any sharp radius in tubing that may kink over time. Route tubing away from heat (exhaust manifolds etc.) and fasten securely. See your tubing manufacturer for recommendations.
- Always use high quality non-corrosive fittings, valves and hardware to assure long-term reliability.
- The through hull fitting **must** have a sea-cock valve to shut-off in case of an emergency.
- Properly seal all pipe threads before the strainer to prevent unforeseen leaks, **Never** use Teflon tape or sealing compounds on SHURflo fittings. Sealant may enter the pump causing a failure not covered under warranty.

TYPICAL POTABLE WATER INSTALLATION:

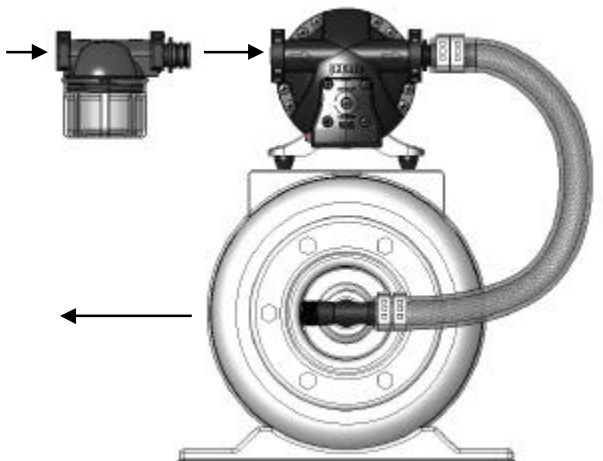

TYPICAL WASHDOWN INSTALLATION:

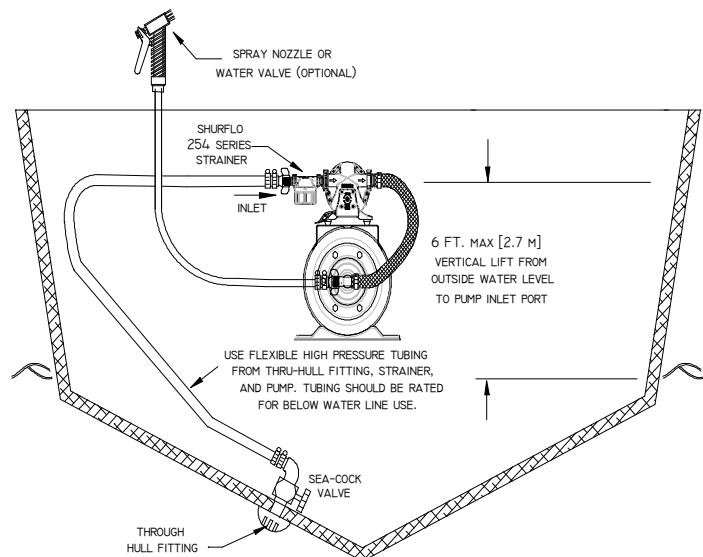

FITTINGS INTALLATION INSTRUCTIONS

SHURflo quick connect fittings provide easy installation and removal if required. The fittings are designed with dual o-rings, creating a seal when snapped into place.



Pump clip original stage.

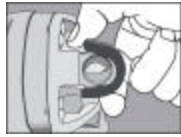

Step #1:
Place your thumb at the edge of the clip as shown.



Step #2:
Using your thumb, pry up edge of lock clip over lock tab. (as shown)



Step #3:
Insert strainer or fitting into quick connect port, push all the way until stops.



Step #4:
Place your thumb on top of the clip as shown.



Step #5:
Snap lock clip over fitting and lock. Pull fitting to make sure is locked in to place.

STRAINER

Installation of a 40-mesh minimum strainer such as SHURflo series 254 (included with system) is necessary to prevent debris entering the pump. System failure due to debris is not covered by SHURflo warranty.

- The strainer **MUST** be mounted on the inlet side of the pump. The directional flow for the water inlet is marked with an arrow on the pump head and on the strainer.
- Mount the strainer where it can be inspected and cleaned easily. The strainer can be mounted directly on the pump inlet port or it can also be mounted away from the pump by using the bracket and fittings supplied (see figure below).
- System is not rated for below waterline installation. The strainer and pump **must** be mounted above the outside water line.

Raw Water Strainers Available (Sold Separately)

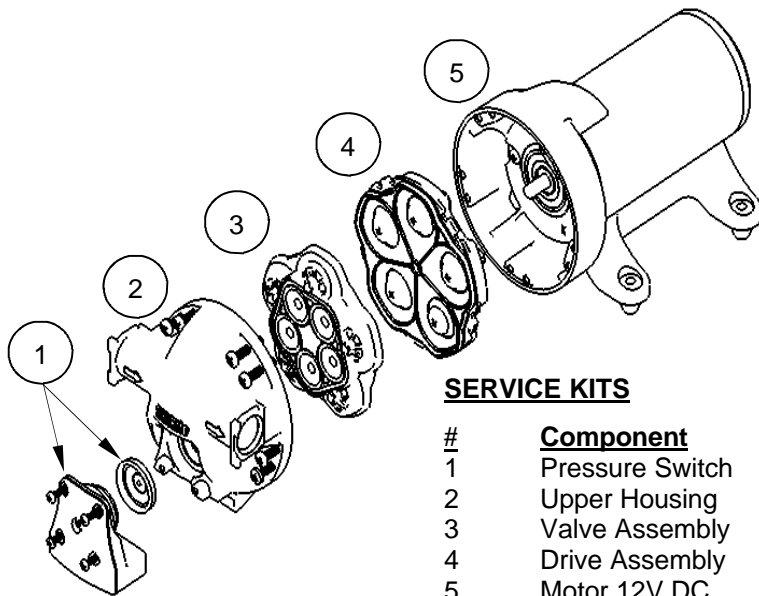
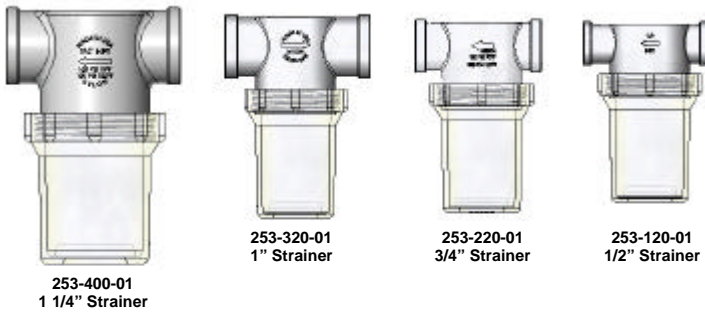

SERVICE KITS

#	Component	Part Kit #:
1	Pressure Switch	94-069-00
2	Upper Housing	94-670-02
3	Valve Assembly	94-030-01
4	Drive Assembly	94-030-02
5	Motor 12V DC	77-007-17
5	Motor 24V DC	77-009-17
5	Motor 32V DC	77-010-17

FITTING KITS (Sold Separately)

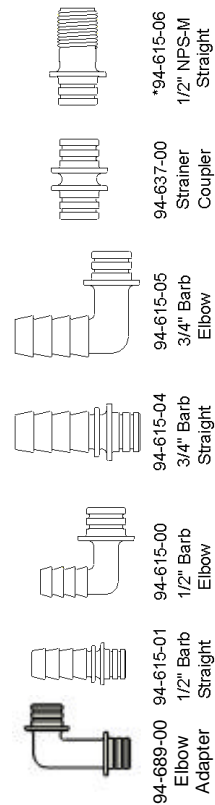

* Included with Aftermarket Extreme Pro Blaster pump kits.

CAUTION

ELECTRICAL WIRING

- Electrical wiring should be performed in accordance with applicable marine electrical codes.
- Electrical connections should be insulated or water proof to prevent shorts and corrosion. Wiring should be routed away from areas prone to water, heat and excess moisture.
- The pump should be on a dedicated (individual) circuit, controlled with a switch (UL/CUL) certified higher than the fuse ampere indicated on the pump motor label (refer to the chart below for proper wire size). Depending on distance of the power source from the pump and ampere load on the circuit, wire size may need to be heavier than indicated by the chart.
- This is an intermittent duty pump. Improper duty cycle and/or rapid start and stop conditions may result in premature motor failure due to excessive heat.
- This motor is equipped with an internal thermal protector, it will shut-down if temperature conditions reach its maximum limitations. It must be allowed to cool down for restart. After cooling down it will automatically restart.
- For the pump to meet UL/C-UL requirements, the circuit MUST be protected with a fuse or a UL/C-UL certified or equivalent circuit breaker (refer to the pump label for fuse size).

ELECTRICAL INSTALLATION:

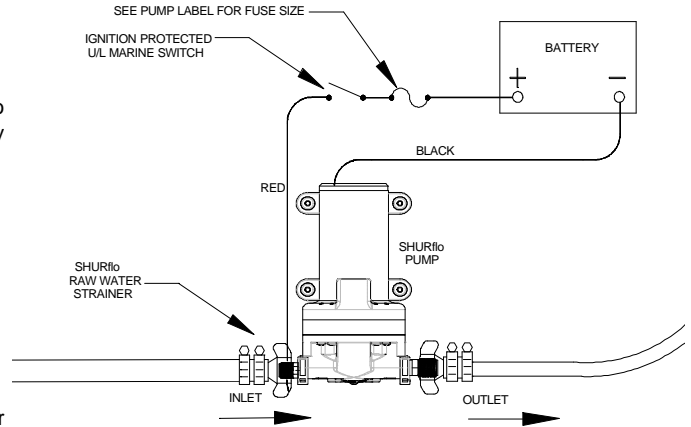

Wire sizing for 10% Voltage Drop (Distance from pump to voltage source and back)

VOLTAGE	TOTAL CURRENT	WIRE SIZE	WIRE LENGTH	FUSE RATING
12 VDC	15 Amps	# 14	max of 25 ft [7.6M]	See Motor Label
		# 12	max of 40 ft [12.1M]	See Motor Label
		# 10	max of 60 ft [18.2M]	See Motor Label
		# 8	max of 110 ft [33.5M]	See Motor Label
VOLTAGE	TOTAL CURRENT	WIRE SIZE	WIRE LENGTH	FUSE RATING
24 VDC	6 Amps	# 16	max of 25 ft [7.6M]	See Motor Label
		# 14	max of 40 ft [12.1M]	See Motor Label
		# 12	max of 60 ft [18.2M]	See Motor Label
		# 10	max of 100 ft [30.4M]	See Motor Label
VOLTAGE	TOTAL CURRENT	WIRE SIZE	WIRE LENGTH	FUSE RATING
32 VDC	5 Amps	# 16	max of 25 ft [7.6M]	See Motor Label
		# 14	max of 40 ft [12.1M]	See Motor Label
		# 12	max of 60 ft [18.2M]	See Motor Label
		# 10	max of 100 ft [30.4M]	See Motor Label

WINTERIZING

If water is allowed to freeze in the system, serious damage to the plumbing and pump/system may occur. Failures of this type will void the warranty. The best guarantee against damage is to completely drain the system. To properly drain the system perform the following:

- Drain the water tank. If the tank doesn't have a drain valve, open all faucets and let pump run until tank is empty.
- Open all the faucets (including the lowest valve or drain in the plumbing) and allow the pump to purge the water from the plumbing system, and then turn the pump OFF.
- All faucets should be left open to guard against any damage.
- Potable water anti-freeze may be poured into drains to protect p-traps and waste system from freezing.
- Fill system and sanitize before re-use.

SANITIZING:

Mix a solution of 3 tablespoons of sodium hypochlorite (house hold bleach) per 10 gallon tank capacity. Pour solution into tank. Fill tank. Run all fixtures for one minute to fill water lines. Allow to sit 4 hours minimum. Flush system. To shorten time to 1 hour, double the bleach concentration.

SYSTEM SPECIFICATIONS:

Voltage:	12V DC	24V DC	32V DC
Maximum Amps:	15 Amps	6 Amps	5 Amps
Fuse Size:	25 Amp	10 Amp	10 Amp
Open Flow:	5.6 GPM [21lt/m]	5.6 GPM [24lt/m]	5.6 GPM [24lt/m]
Pressure Switch:	OFF = 45 PSI [3.1 bar]	OFF = 45 PSI [3.1 bar]	OFF = 45 PSI [3.1 bar]
Inlet Port Configuration:	3/4" Barb	3/4" Barb	3/4" Barb
Outlet Port Configuration:	1/2" - 14 NPSM	1/2" - 14 NPSM	1/2" - 14 NPSM
Duty Cycle:	Intermittent	Intermittent	Intermittent
Ambient Temp. Range:	33° - 130°F [0.5° - 54°C]	33° - 130°F [0.5° - 54°C]	33° - 130°F [0.5° - 54°C]
Maximum Inlet Pressure:	30 PSI [2.0 bar]	30 PSI [2.0 bar]	30 PSI [2.0 bar]
Ignition Protected:	UL Marine/ISO 8846	UL Marine/ISO 8846	UL Marine/ISO 8846
Tank Mounting Holes:	4-13/16" x 8-5/8" center to center [12.2cm x 21.9 cm]	4-13/16" x 8-5/8" center to center [12.2cm x 21.9 cm]	4-13/16" x 8-5/8" center to center [12.2cm x 21.9 cm]

ACCUMULATOR TANK SPECIFICATION:

Maximum Working Pressure	50 PSI [3.4 bar]
Total Volume	2 gal. [7.6 lt]
Temperature Range	34-120° F [1-49°C]
Tank Material	Stainless Steel
Bladder Material	Butyl
Listing	NSF Standard 18

TO CHECK TANK AIR CHARGE:

- Shut-off electric power to pump, open faucet near tank, and drain completely.
- At air valve, check precharge with tire gauge. Precharge should be at pump "turn ON" pressure setting.
- If pressure is more than 2 psi [14 kPa] below the "turn ON" pressure, add air to tank. Use compressor or potable air storage tank. If precharge is above "turn ON" pressure, bleed off the appropriate amount.
- Use soap or liquid detergent to check for air leaks around the air valve. Continuous bubbling indicates leak. If necessary, install a new core in air valve (same as used for automotive tires) .
- If tank is filled with water (waterlogged), the bladder is leaking. This condition cannot be repaired. Replacement of tank is necessary.

LIMITED WARRANTY

SHURflo warrants The 5902 Extreme series pump accumulator system to be free from material and workmanship defects under normal use and service for a period of (3) three years from the date of purchase. In the absence of proof of purchase the warranty is (3) three years from the date of manufacture indicated on the motor nameplate, not to exceed three years in any event. Pumps used in commercial applications are warranted for six months from date of purchase only (proof required). The limited warranty will not apply to pumps that were improperly installed, misapplied, or incompatible with components not manufactured by SHURflo. Pump failure due to foreign debris is not covered under the terms of this limited warranty. SHURflo will not warrant any pump that is physically damaged, or altered outside the SHURflo factory. Warranty claims may be resolved by an authorized dealer service center, or by a SHURflo service center. All returns are to be shipped with charges pre-paid. Package all returns carefully. SHURflo will not be responsible for freight damage incurred during shipping to a service center. SHURflo's obligation under this warranty policy is limited to the repair or replacement of the pump. Pumps found not defective (under the terms of this limited warranty) are subject to charges to be paid by the returnee for the testing and packaging of "tested good" units. Warranty returns will be shipped on a freight allowed basis. SHURflo reserves the right to choose the method of transportation. SHURflo is not responsible nor will it reimburse for labor necessary to remove and reinstall a pump, if found defective. This warranty is only a representation of the complete Marine Products Limited Warranty outlined by Service Bulletin #1050.



- ES** Favor de referirse a www.shurflo.com para instrucciones de la instalación del producto y su operación, disponible en varios idiomas.
- DE** Mehrsprachige Hinweise zu Installation und Betrieb des Produktes finden Sie unter www.shurflo.com
- IT** Fare riferimento al sito www.shurflo.com per manuali multilingue di installazione ed utilizzo prodotti.
- FR** Veuillez vous référer au site www.shurflo.com pour l'installation produit multilingue ainsi que pour le mode d'emploi.
- UK** Please refer to www.shurflo.com for multi-lingual product installation and operating instructions'

SHURflo reserves the right to update specifications, prices, or make substitutions.

**SHURflo, LLC Headquarters**

5900 Katella Avenue
Cypress, California 90630
Phone (562) 795-5200 • Toll Free (800) 854-3218
Fax (562) 795-7564

SHURflo, LLC East

52748 Park Six Court
Elkhart, Indiana 46514-5427
Phone (562) 795-5200 • Toll Free (800) 854-3218
Fax (574) 264-2169

SHURflo Europe, Middle East, Africa

Pentair Water Belgium bvba,
Industriepark Wolfstee, Toekomstlaan 30
B-2200 Herentals, Belgium
Phone +32-14-283500 • Fax +32-14-283505