



**MARINE** PRODUCT DATA SHEET

DEM: 254-066  
 AFTERMARKET: 254-266

SHURflo highly recommends the use of the Extreme Series High Flow Strainer, engineered to compliment the higher performance of the Smart Sensor, to keep your Extreme Series Pumps flowing strong by protecting it from debris in the water. Easy installation and even easier to clean. Available with or without bracket.

**TYPICAL APPLICATIONS**

Fresh water pump debris strainer. Vacuum side application only. For other applications contact SHURflo.

**MATERIAL**

O-Ring: EPDM  
 Mesh Housing: Polycarbonate  
 Screen: 50 Mesh Stainless Steel  
 Cover: Nylon 6

**SPECIFICATIONS**

Inlet Port: Quick Connect w/ SHURflo fittings  
 Outlet Port: Quick Connect w/ SHURflo fittings  
 Max Temp: 120°F [48°C]  
 Max Pressure: Vacuum Side Only

**APPROVALS**

IAPMO [Meets NSF 61]

**WARRANTY**

1 Year Limited Warranty  
 See SB-1041 and SB-1050 for Warranty details

**RELATED DOCUMENTS**

Catalog: MS-030-140 / MS-030-083  
 Installation Manual: 911-617  
 Maintenance: 911-617  
 Applications Spec Guide: MS-020-005  
 Warranty: SB-1041 / SB-1050

Exploded View—Parts Kits Not Available

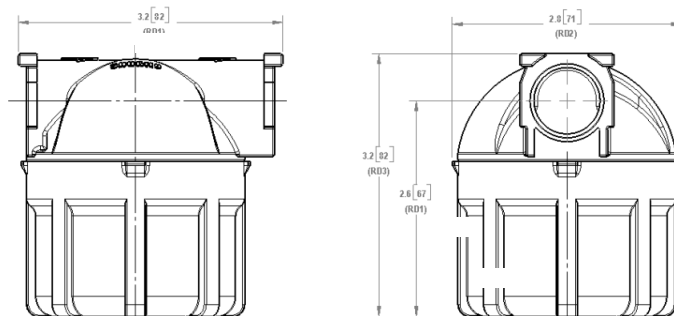

SHURflo reserves the right to update specifications, prices, or make substitutions.



**SHURflo, LLC Headquarters**

5900 Katella Avenue  
 Cypress, California 90630  
 Phone (562) 795-5200 • Toll Free (800) 854-3218  
 Fax (562) 795-7564

**SHURflo, LLC East**

52748 Park Six Court  
 Elkhart, Indiana 46514-5427  
 Phone (562) 795-5200 • Toll Free (800) 854-3218  
 Fax (574) 264-2169

**SHURflo Europe, Middle East, Africa**

**Pentair Water Belgium bvba,**  
 Industriepark Wolfstee, Toekomstlaan 30  
 B-2200 Herentals, Belgium  
 Phone +32-14-283500 • Fax +32-14-283505