

MARINE PRODUCT DATA SHEET

OEM: 253-220-00 (Raw Water Strainer)
AFTERMARKET: 253-220-01 (Raw Water Strainer)

APPLICATION

Raw water pump debris strainer.
Vacuum side application only

MATERIAL:

Gasket: Buna
Housing: Nylon
Bowl: Polymide
Screen: 50 Mesh T304 Stainless Steel

SPECIFICATIONS

Inlet Port: 3/4" NPT-F
Outlet Port: 3/4" NPT-F
Max. Temp: 120°F [48°C]
Max PSI: Vacuum Side Only

WARRANTY

1 Year Limited Warranty.
Contact SHURflo for details

RELATED DOCUMENTS

Catalog: MS-030-140
Installation Manual: N/A
Applications Spec Guide: MS-020-005



SHURflo's family of Raw Water Strainers are built to keep your bait tank, livewell and washdown pumps protected from harmful debris. The Raw Water Strainer features a clear twist off bowl and removable stainless steel screen, which allows for easy inspection and cleaning. An integral o-ring creates a tight seal, eliminating possible leaks. Keep your pumps and components lasting longer by protecting them with the SHURflo Raw Water Strainer.

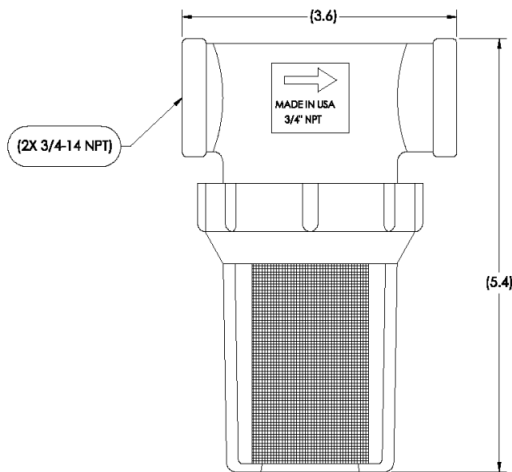

Repair Kits

Number	Description	Part Number
1	Screen	94-726-00

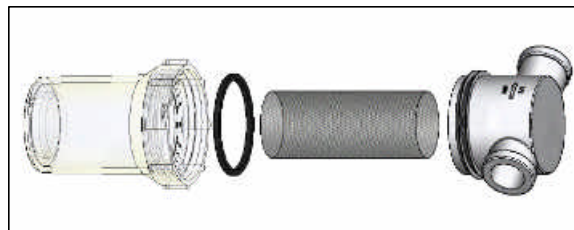

Visit our Web Site at <http://www.shurflo.com>
Shurflo reserves the right to update specifications,
change prices, or make substitutions without notice.

SHURflo
5900 Katella Avenue
Cypress, CA 90630
Phone (562) 795-5200
Toll Free (800) 854-3218
Fax (562) 795-7564

SHURflo East
52748 Park Six Court
Elkhart, IN 46514-5427
Phone (562) 795-5200
Toll Free (800) 854-3218
Fax (574) 264-2169

SHURflo Europe, Middle East, Africa
Pentair Water Belgium bvba
Industriepark Wolfstee, Toekomstlann 30
B-2200 Herentals, Belgium
Phone +32-14-283500
Fax +32-14-283505



Pentair Water
FLOW TECHNOLOGIES GROUP
5900 Katella Ave, Cypress, CA 90630
Phone (800) 854-3218 • (562) 795-5200 • Fax (562) 795-7564
www.shurflo.com