

# MARINE PRODUCT DATA SHEET

**OEM:** 253-320-00 (Raw Water Strainer)  
**AFTERMARKET:** 253-320-01 (Raw Water Strainer)

## APPLICATION

Raw water pump debris strainer.  
 Vacuum side application only

## MATERIAL:

Gasket: Buna  
 Housing: Nylon  
 Bowl: Polyimide  
 Screen: 50 Mesh T304 Stainless Steel

## SPECIFICATIONS

Inlet Port: 1" NPT-F  
 Outlet Port: 1" NPT-F  
 Max. Temp: 120°F [48°C]  
 Max PSI: Vacuum Side Only

## WARRANTY

1 Year Limited Warranty.  
 Contact SHURflo for details

## RELATED DOCUMENTS

Catalog: MS-030-140  
 Installation Manual: N/A  
 Applications Spec Guide: MS-020-005

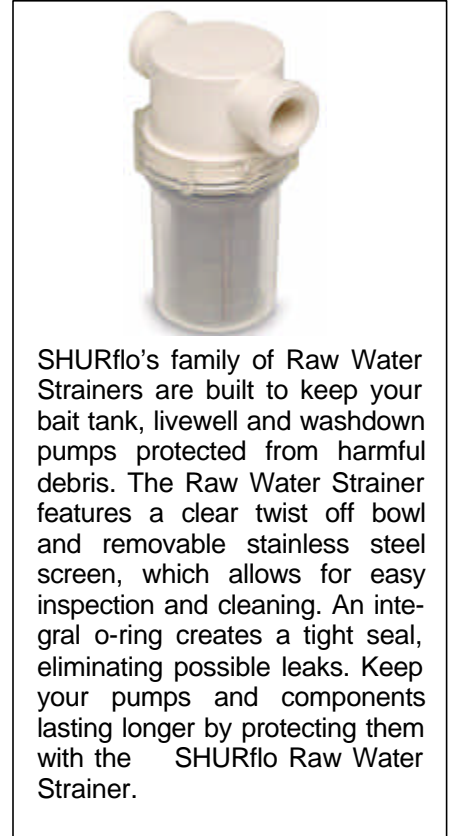

SHURflo's family of Raw Water Strainers are built to keep your bait tank, livewell and washdown pumps protected from harmful debris. The Raw Water Strainer features a clear twist off bowl and removable stainless steel screen, which allows for easy inspection and cleaning. An integral o-ring creates a tight seal, eliminating possible leaks. Keep your pumps and components lasting longer by protecting them with the SHURflo Raw Water Strainer.

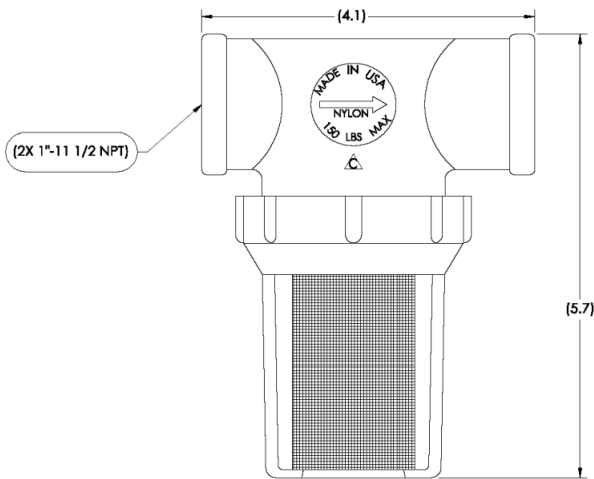

## Repair Kits

Number	Description	Part Number
1	Screen	94-726-00

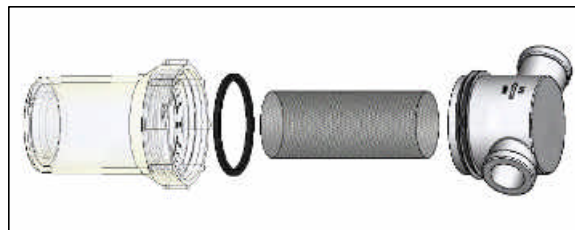

Visit our Web Site at <http://www.shurflo.com>  
 Shurflo reserves the right to update specifications,  
 change prices, or make substitutions without notice.

**SHURflo**  
 5900 Katella Avenue  
 Cypress, CA 90630  
 Phone (562) 795-5200  
 Toll Free (800) 854-3218  
 Fax (562) 795-7564

**SHURflo East**  
 52748 Park Six Court  
 Elkhart, IN 46514-5427  
 Phone (562) 795-5200  
 Toll Free (800) 854-3218  
 Fax (574) 264-2169

**SHURflo Europe, Middle East, Africa**  
**Pentair Water Belgium bvba**  
 Industriepark Wolfstee, Toekomstlann 30  
 B-2200 Herentals, Belgium  
 Phone +32-14-283500  
 Fax +32-14-283505



**Pentair Water**  
**FLOW TECHNOLOGIES GROUP**  
 5900 Katella Ave, Cypress, CA 90630  
 Phone (800) 854-3218 • (562) 795-5200 • Fax (562) 795-7564  
[www.shurflo.com](http://www.shurflo.com)