

MARINE PRODUCT DATA SHEET

OEM: 357-112-00 (800 GPH)

AFTERMARKET: 357-112-10 (800 GPH)

APPLICATION

12V DC Bait/Livewell tanks water circulation

PUMP

Type: Centrifugal Pump
Outlet Port: 3/4" Barb
Inlet Port: 3/4" NPS-M
Liquid: 130 °F [54 °C] Max
Prime: Flooded Inlet
Inlet PSI: 30 PSI [2.1 Bar] Max
Run Dry: No

ELECTRICAL

Motor: 12VDC Permanent Magnet,
Continuous Duty
Protection: Need External Fuse (Not supplied)
Leads: 6 ft [1.8M] Tinned, 16 AWG
Fuse: 6 Amp Recommended
Control: No Control

MATERIALS

Housing: High Strength Nylon
Impeller: High Strength Nylon
Hardware: Stainless Steel

APPROVALS

Ignition Protected 8846, CE

WARRANTY

2 Year Limited Warranty. Contact SHURflo for details

SHIPPING

Net Weight (unboxed): 1.5 Lb [0.68 Kg] each
Approx. Lbs./Ctn. 27 Lb [12.2 Kg]
Pumps in Carton: 18
Carton Size: 24"L x 18"W x 11" H
[61cm x 46 cm x 28 cm]

RELATED DOCUMENTS

Catalog: MS-030-140
Installation Manual: 911-611
Applications Spec Guide: MS-020-005



Everything you are looking for in an aerator pump. Our tough, high density nylon housing and heavy duty water cooled motor give the SHURflo Aerator Pumps unparalleled reliability. Patented anti-airlock feature allows the pump to clear trapped air in rough water or when the boat is anchored. All Piranha Series Aerator Pumps have a removable cartridge for easy cleaning.

Replacement Kit

94-620-00



TYPICAL PERFORMANCE

PRESSURE		FLOW		CURRENT
METERS	FT OF HEAD	GPH	LPH	AMPS
0.0	0	800	3028	2.7
1.80	6	240	908	2.8
3.65	12	0.0	0.0	2.4

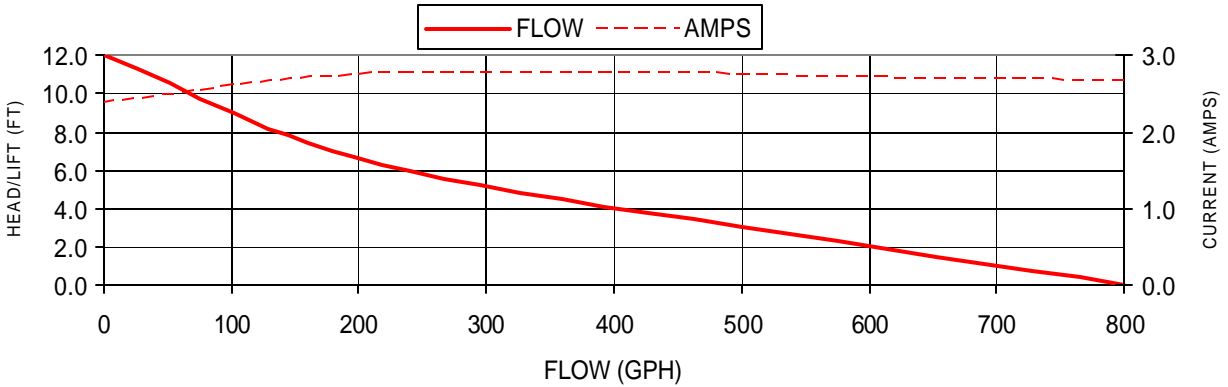

DIMENSIONS [mm]

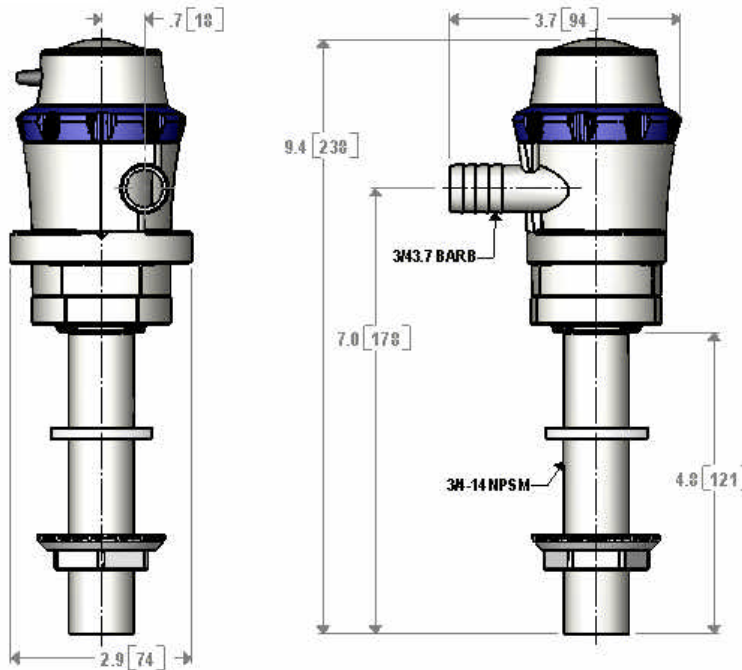

Visit our Web Site at <http://www.shurflo.com>

Shurflo reserves the right to update specifications, change prices, or make substitutions without notice.



SHURflo
5900 Katella Avenue
Cypress, CA 90630
Phone (562) 795-5200
Toll Free (800) 854-3218
Fax (562) 795-7564

SHURflo East
52748 Park Six Court
Elkhart, IN 46514-5427
Phone (562) 795-5200
Toll Free (800) 854-3218
Fax (574) 264-2169

SHURflo Europe, Middle East, Africa
Pentair Water Belgium bvba
Industriepark Wolfstee, Toekomstlaan 30
B-2200 Herentals, Belgium
Phone +32-14-283500
Fax +32-14-283505



Pentair Water

FLOW TECHNOLOGIES GROUP

5900 Katella Ave, Cypress, CA 90630
Phone (800) 854-3218 • (562) 795-5200 • Fax (562) 795-7564
www.shurflo.com