



## MARINE PRODUCT DATA SHEET

OEM: 357-102-00 (1100 GPH)  
AFTERMARKET: 357-102-10 (1100 GPH)

Everything you are looking for in an aerator pump. Our tough, high density nylon housing and heavy duty water cooled motor give the SHURflo Aerator Pumps unparalleled reliability. Patented anti-airlock feature allows the pump to clear trapped air in rough water or when the boat is anchored. All Piranha Series Aerator Pumps have a removable cartridge for easy cleaning.

### TYPICAL APPLICATIONS

12V DC Bait/Livewell Application. For other applications, contact SHURflo.

### PUMP

Type: Centrifugal Pump  
Port (Outlet): 1 1/8" Barb  
Port (Inlet): 3/4" NPS-M  
Liquid: 130 °F [54 °C] Max  
Prime: Flooded Inlet  
Inlet PSI: 30 PSI [2.1 Bar] Max  
Run Dry: No

### ELECTRICAL

Motor: 12VDC Permanent Magnet, Continuous Duty  
Protection: External Fuse  
Leads: 6 ft (1.8M) Tinned, 16 AWG  
Fuse: 6 Amp Recommended  
Control: No Control

### MATERIALS

Housing: High Strength Nylon  
Impeller: high Strength Nylon  
Hardware: Stainless Steel

### APPROVALS

Ignition Protected, CE, ISO 8846

### WARRANTY

2 Year Limited Warranty  
See SB-1050 For Full Warranty Details

### SHIPPING

Net Weight (Boxed): 1.5 Lb (0.68 Kg) each  
Carton Weight: 27 Lb [12.2 Kg]  
Pumps in Carton: 18  
Carton Size: 24"L x 18"W x 11" H [61 cm x 46 cm x 28 cm]

### RELATED DOCUMENTS

Catalog: MS-030-140  
Installation Manual: 911-611-00  
Maintenance: 911-611-00  
Applications Spec Guide: MS-020-005  
Warranty: SB-1050

### Replacement Kit

94-620-00

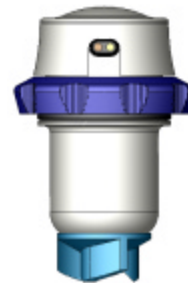

PERFORMANCE @ 13.6V DC

PRESSURE		FLOW		CURRENT
METERS	FT OF HEAD	GPH	LPH	AMPS
0.0	0	1242	4700	4.80
1.80	6	420	1590	3.84
3.30	11	0.0	0.0	2.57

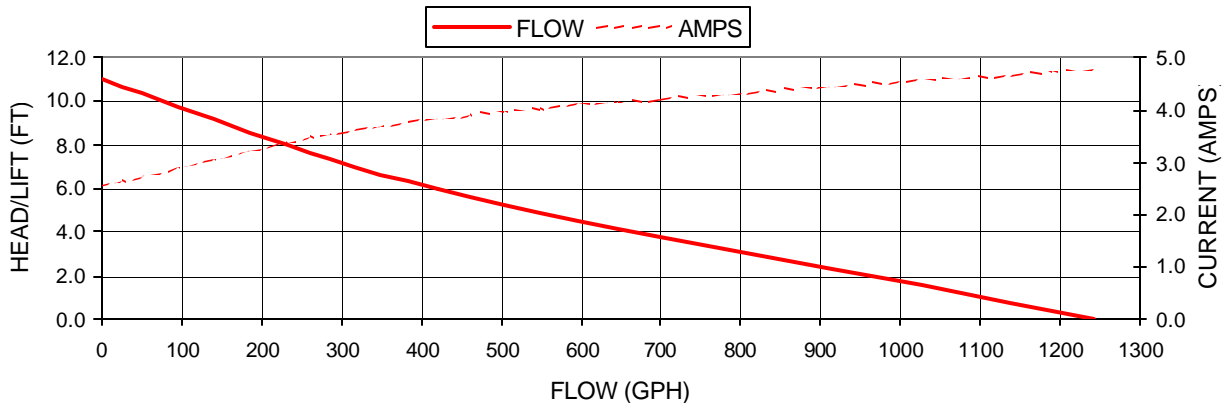

DIMENSIONS [mm]

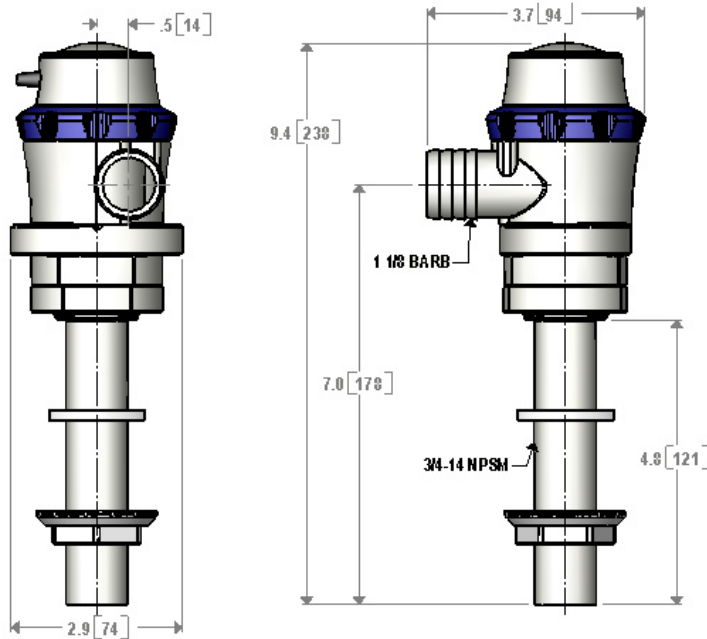

SHURflo reserves the right to update specifications, prices, or make substitutions.



**SHURflo, LLC Headquarters**

5900 Katella Avenue  
 Cypress, California 90630  
 Phone (562) 795-5200 • Toll Free (800) 854-3218  
 Fax (562) 795-7564

**SHURflo, LLC East**

52748 Park Six Court  
 Elkhart, Indiana 46514-5427  
 Phone (562) 795-5200 • Toll Free (800) 854-3218  
 Fax (574) 264-2169

**SHURflo Europe, Middle East, Africa**

**Pentair Water Belgium bvba,**  
 Industriepark Wolfstee, Toekomstlaan 30  
 B-2200 Herentals, Belgium  
 Phone +32-14-283500 • Fax +32-14-283505