

MARINE PRODUCT DATA SHEET

OEM: 357-104-00 (1100 GPH)

AFTERMARKET: 357-104-10 (1100 GPH)

APPLICATION

12V DC Bait/Livewell tanks water circulation

PUMP

Type: Centrifugal Pump
Outlet Port: 1-1/8" Barb
Inlet Port: 3/4" NPS-M
Liquid: 130 °F [54 °C] Max
Prime: Flooded Inlet
Inlet PSI: 30 PSI [2.1 Bar] Max
Run Dry: No

ELECTRICAL

Motor: 12VDC Permanent Magnet,
Continuous Duty
Protection: Need External Fuse (Not supplied)
Leads: 6 ft [1.8M] Tinned, 16 AWG
Fuse: 6 Amp Recommended
Control: No Control

MATERIALS

Housing: High Strength Nylon
Impeller: High Strength Nylon
Hardware: Stainless Steel

APPROVALS

Ignition Protected 8846, CE

WARRANTY

2 Year Limited Warranty. Contact SHURflo for details

SHIPPING

Net Weight (unboxed): 1.5 Lb [0.68 Kg] each
Approx. Lbs./Ctn. 27 Lb [12.2 Kg]
Pumps in Carton: 18
Carton Size: 24"L x 18"W x 11" H
[61cm x 46 cm x 28 cm]

RELATED DOCUMENTS

Catalog: MS-030-140
Installation Manual: 911-611
Applications Spec Guide: MS-020-005



Replacement Kit

94-620-00



TYPICAL PERFORMANCE

PRESSURE		FLOW		CURRENT
METERS	FT OF HEAD	GPH	LPH	AMPS
0.0	0	1014	3837	4.60
2.4	8	330	1249	3.64
3.9	13	0.0	0.0	3.15

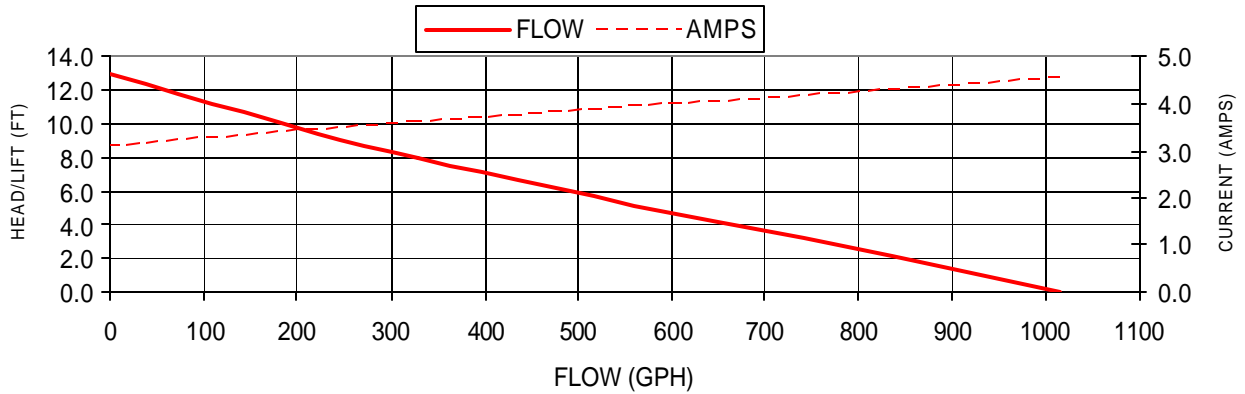

DIMENSIONS [mm]

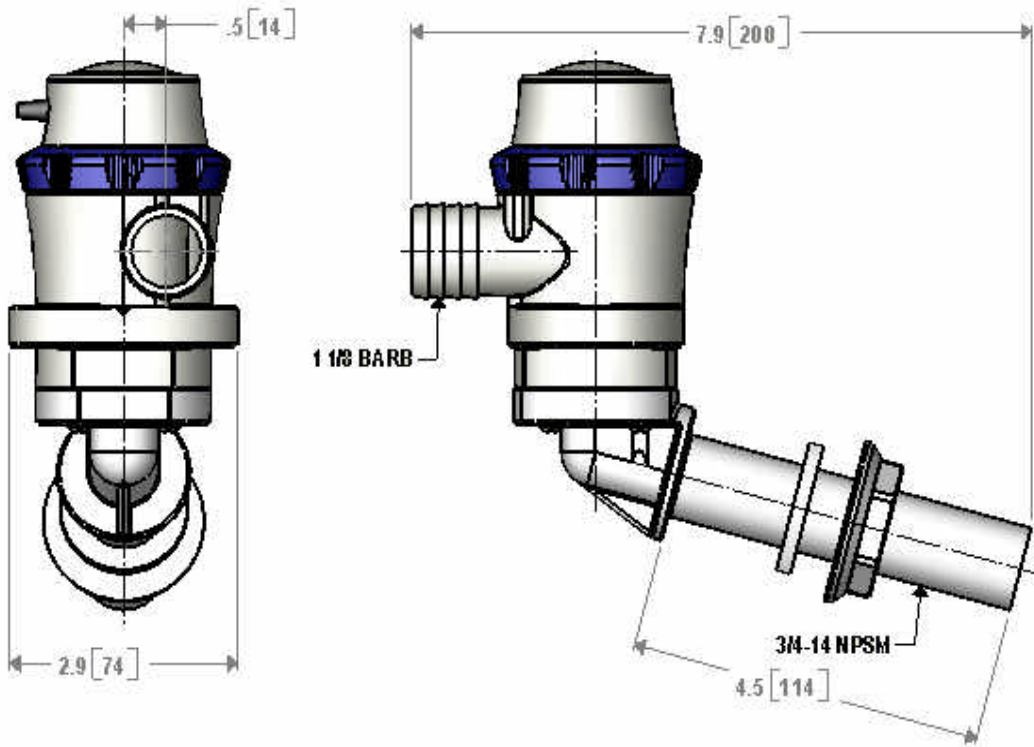

Visit our Web Site at <http://www.shurflo.com>
 Shurflo reserves the right to update specifications,
 change prices, or make substitutions without notice.



Pentair Water

FLOW TECHNOLOGIES GROUP

5900 Katella Ave, Cypress, CA 90630
 Phone (800) 854-3218 • (562) 795-6200 • Fax (562) 795-7564
www.shurflo.com

SHURflo
 5900 Katella Avenue
 Cypress, CA 90630
 Phone (562) 795-5200
 Toll Free (800) 854-3218
 Fax (562) 795-7564

SHURflo East
 52748 Park Six Court
 Elkhart, IN 46514-5427
 Phone (562) 795-5200
 Toll Free (800) 854-3218
 Fax (574) 264-2169

SHURflo Europe, Middle East, Africa
Pentair Water Belgium bvba
 Industriepark Wolfstee, Toekomstlaan 30
 B-2200 Herentals, Belgium
 Phone +32-14-283500
 Fax +32-14-283505