

MARINE PRODUCT DATA SHEET

OEM: 8050-305-526 (Utility Pump)
AFTERMARKET: 8050-305-526 (Utility Pump)

APPLICATION

12V DC Oil change, winterizing, automatic transmission fluids, anti-freeze solutions, low viscosity gear and liquid transfer. Other uses may include 12 VDC pressurized water systems.

PUMP:

Type: 3 Chamber Diaphragm
Ports: 3/8" NPT-F.
Liquid: 180 °F [82 °C] Max
Dry-Prime: 6 feet [1.82 M]
Inlet PSI: 30 PSI [2.1 Bar] Max
Run Dry: Yes

ELECTRICAL:

Motor: 12VDC Permanent Magnet, Continuous Duty
Protection: Thermal Overload, Automatic Restart
Leads: 16 AWG, 16" [40 cm] Red +, 13" [33 cm] Black -
Fuse: 7.5 Amp Recommended
Control: 30 PSI Internal By-pass

MATERIALS:

Housing: Polypro
Valves: Buna
Diaphragm: Geolast
Hardware: Stainless Steel

APPROVALS:

Ignition Protection 8846, CE

WARRANTY:

1 Year Limited Warranty.
Contact SHURflo for details

SHIPPING:

Net Weight: 4 Lb [1.8 Kg] each
Carton Quantity: 6
Carton Weight: 28 Lb [12.7 Kg]
Carton Size: 24"L x 18"W x 6"H
[61cm x 46cm x 15cm]

RELATED DOCUMENTS:

Catalog: MS-030-140
Installation Manual: 911-714
Maintenance: 911-314
Applications Spec Guide: MS-020-005



Incorporating SHURflo's advance motor technology that includes thermal overload protection, these pumps are self-priming, easy to install and are extremely versatile-perfect for a variety of uses including winterizing, Oil changing and liquid transfer.

Parts Kits

Number	Components	Parts Kits
9	Motor	94-11-148-06
5a	Valve Assembly	94-391-12
8	Drive Assembly	94-385-42

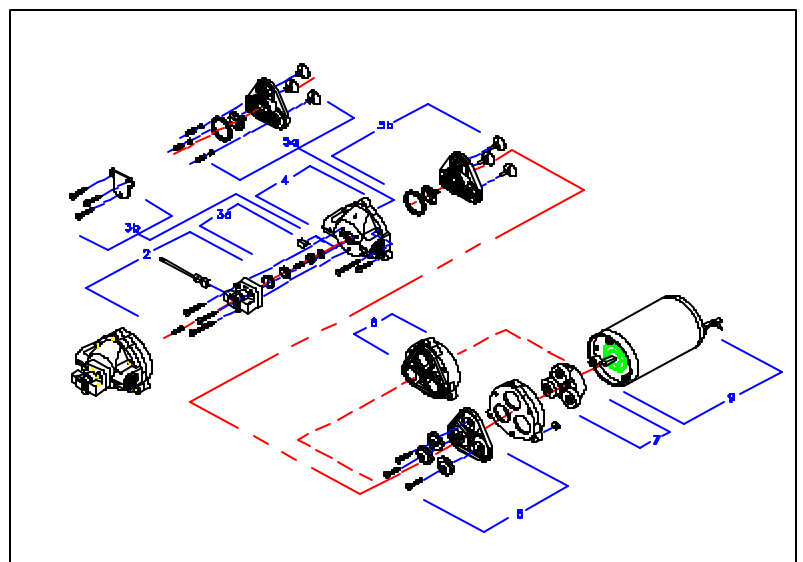

TYPICAL PERFORMANCE WITH WATER

PRESSURE		FLOW		CURRENT
BAR	PSI	GPM	LPM	AMPS
0.0	0	1.55	5.86	2.2
0.7	10	1.45	5.48	2.8
1.4	20	1.36	5.14	3.5
2.1	30	1.10	4.16	4.1
2.8	40	0.15	0.56	4.4

TYPICAL MOTOR SHELL T-RISE @ 40 PSI, 12V

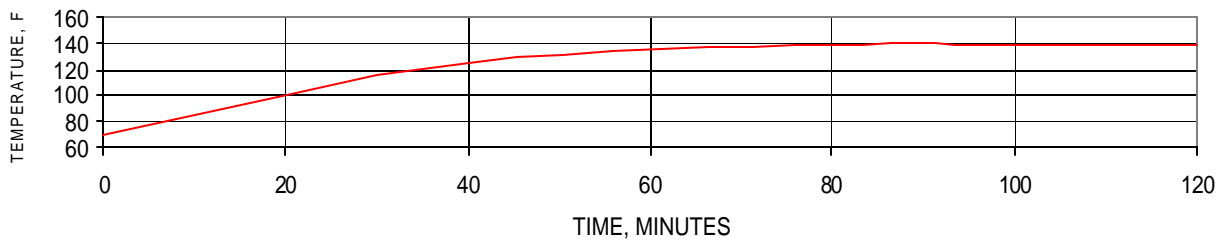

DIMENSIONS [mm]

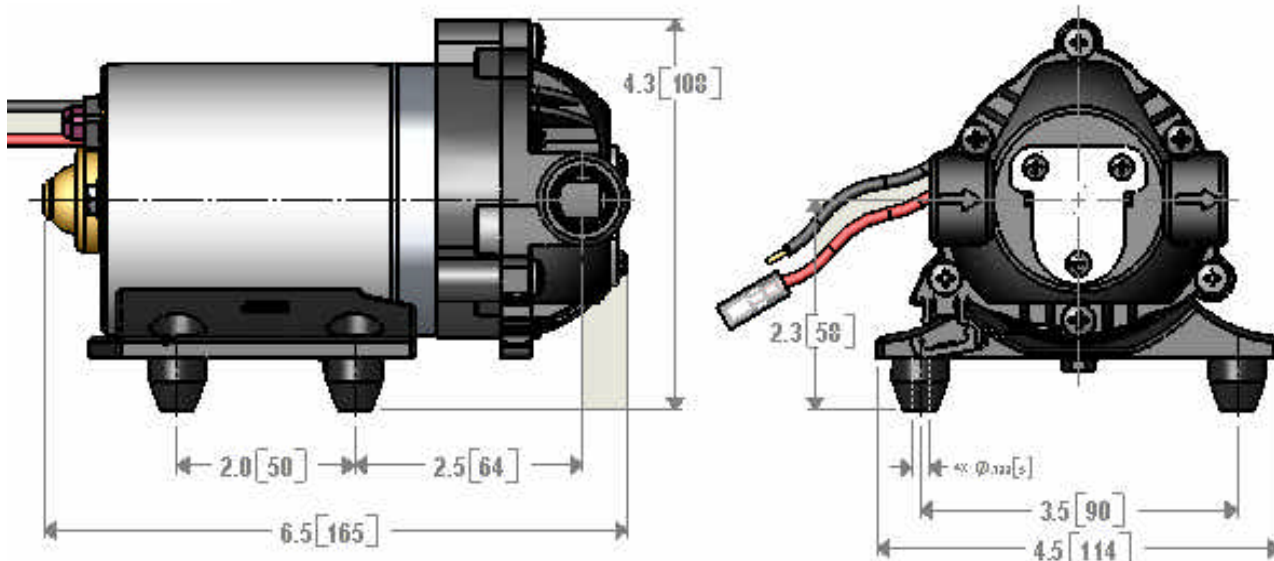

Visit our Web Site at <http://www.shurflo.com>
 Shurflo reserves the right to update specifications,
 change prices, or make substitutions without notice.

SHURflo
 5900 Katella Avenue
 Cypress, CA 90630
 Phone (562) 795-5200
 Toll Free (800) 854-3218
 Fax (562) 795-7564

SHURflo East
 52748 Park Six Court
 Elkhart, IN 46514-5427
 Phone (562) 795-5200
 Toll Free (800) 854-3218
 Fax (574) 264-2169

SHURflo Europe, Middle East, Africa
Pentair Water Belgium bvba
 Industriepark Wolfstee, Toekomstlann 30
 B-2200 Herentals, Belgium
 Phone +32-14-283500
 Fax +32-14-283505



Pentair Water

FLOW TECHNOLOGIES GROUP

5900 Katella Ave, Cypress, CA 90630
 Phone (800) 854-3218 • (562) 795-5200 • Fax (562) 795-7564
www.shurflo.com