

MARINE PRODUCT DATA SHEET

OEM: 8050-261-105 (Utility Pump)
AFTERMARKET: 8050-261-105 (Utility Pump)

APPLICATION

12V DC Refrigeration cold plate circulation.
This pump may be used for general fresh water transfer.

PUMP:

Type: 3 Chamber Diaphragm
Ports: 1/2"-14 NPSM-Male.
Liquid: 130 °F [54 °C] Max
Dry-Prime: 4 feet [1.21 M]
Inlet PSI: 30 PSI [2.1 Bar] Max
Run Dry: Yes

ELECTRICAL:

Motor: 12VDC Permanent Magnet, Continuous Duty
Protection: Thermal Overload, Automatic Restart
Leads: 16 AWG, 16" [40 cm] Red +, 13" [33 cm] Black -
Fuse: 5 Amp Recommended
Control: 45 PSI Internal By-pass

MATERIALS:

Housing: Polypro
Valves: EPDM
Diaphragm: Santoprene
Hardware: Stainless Steel

APPROVALS:

Ignition Protection 8846, CE

WARRANTY:

1 Year Limited Warranty.
Contact SHURflo for details

SHIPPING:

Net Weight: 5.1 Lb [2.3 Kg] each
Carton Quantity: 12
Carton Weight: 62 Lb [28 Kg]
Carton Size: 24"L x 18"W x 11"H
[61cm x 46cm x 28cm]

RELATED DOCUMENTS:

Catalog: MS-030-140
Installation Manual: 911-314
Applications Spec Guide: MS-020-005



Specifically designed for refrigeration cold plate circulation, this pump allows you to adjust water flow according to your system.

Parts Kits

Number	Components	Parts Kits
6	Check Valve	94-374-16
5	Valve Assembly	94-391-06
3 and 4	Drive Assembly	94-385-30

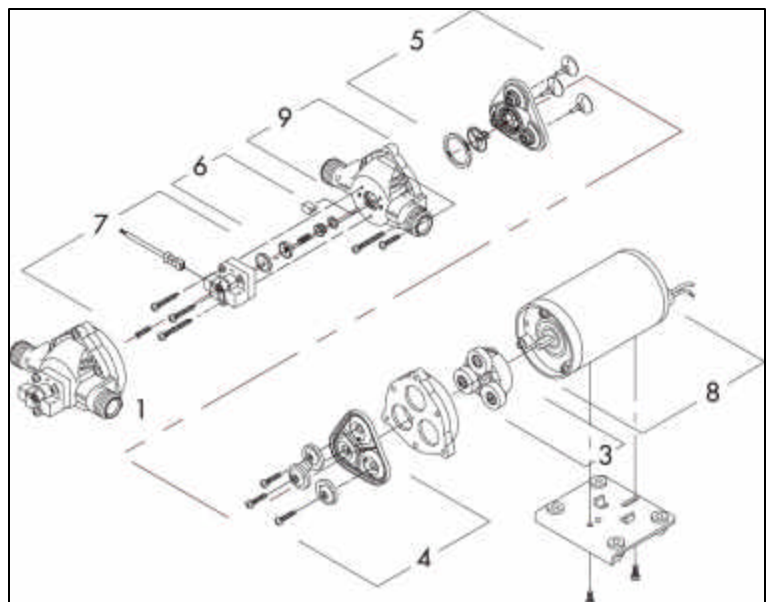

TYPICAL PERFORMANCE

PRESSURE		FLOW		CURRENT
BAR	PSI	GPM	LPM	AMPS
0.0	0	0.60	2.27	0.75
0.7	10	0.55	2.08	1.30
1.4	20	0.51	1.93	1.50
2.1	30	0.42	1.58	1.80

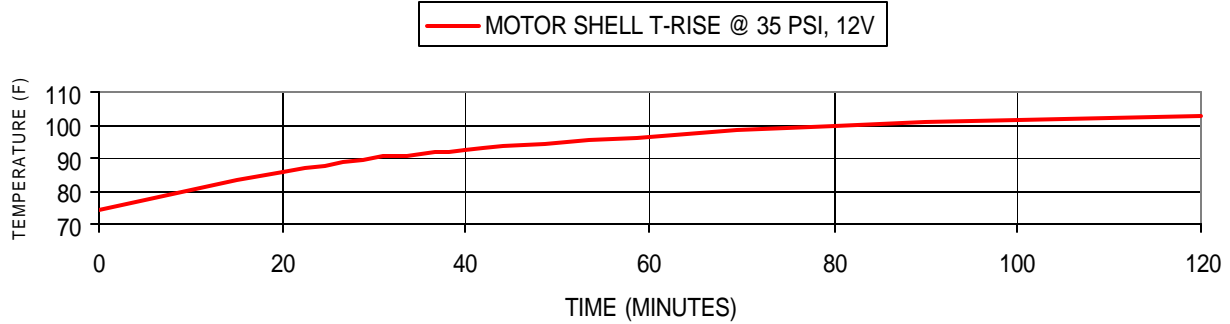

DIMENSIONS [mm]

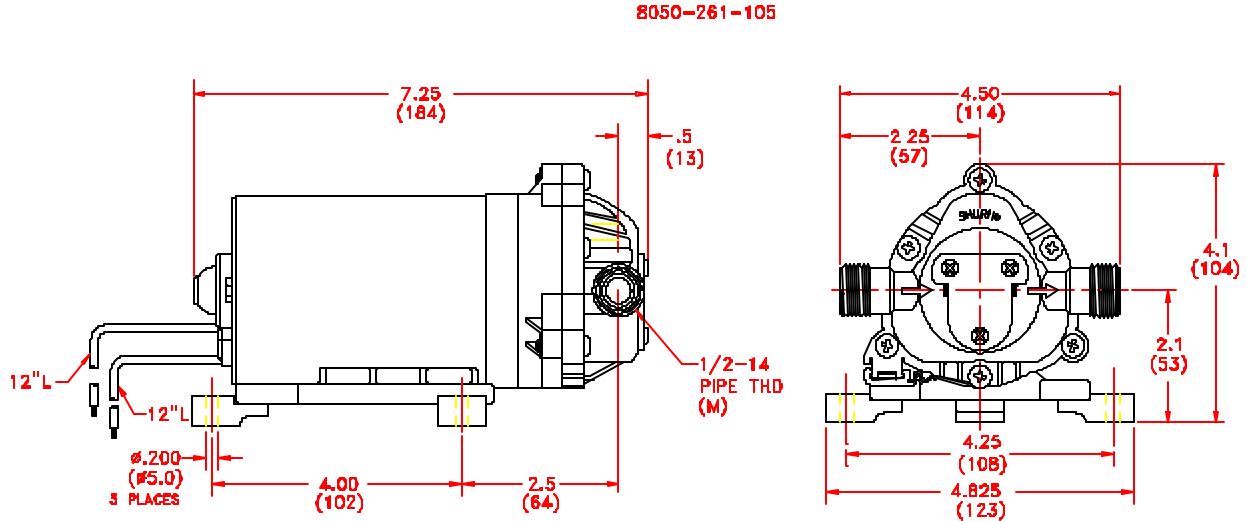

Visit our Web Site at <http://www.shurflo.com>
 Shurflo reserves the right to update specifications,
 change prices, or make substitutions without notice.

SHURflo
 5900 Katella Avenue
 Cypress, CA 90630
 Phone (562) 795-5200
 Toll Free (800) 854-3218
 Fax (562) 795-7564

SHURflo East
 52748 Park Six Court
 Elkhart, IN 46514-5427
 Phone (562) 795-5200
 Toll Free (800) 854-3218
 Fax (574) 264-2169

SHURflo Europe, Middle East, Africa
Pentair Water Belgium bvba
 Industriepark Wolfstee, Toekomstlaan 30
 B-2200 Herentals, Belgium
 Phone +32-14-283500
 Fax +32-14-283505

Pentair Water
FLOW TECHNOLOGIES GROUP
 5900 Katella Ave, Cypress, CA 90630
 Phone (800) 854-3218 • (562) 795-5200 • Fax (562) 795-7564
www.shurflo.com