

MARINE PRODUCT DATA SHEET

OEM: 5902-3212 (High Flow System 5.0)
AFTERMARKET: 5902-3212 (High Flow System 5.0)

APPLICATION

Multi-fixture marine fresh water installations. Other uses may include 24V DC pressurized water systems in cabins. This pump may be used for general fresh water transfer.



PUMP:

Type: 5 Chamber Diaphragm
 Ports: Quick Connect Fittings
 Liquid: 130 °F [54 °C] Max
 Dry-Prime: 6 feet [1.82 M]
 Inlet PSI: 30 PSI [2.1 Bar] Max
 Run Dry: Yes

ELECTRICAL:

Motor: 24VDC Permanent Magnet, Intermittent Duty
 Protection: Thermal Overload, Automatic Restart
 Leads: 14 AWG, 16" [40 cm] Red +, 13" [33 cm] Black -
 Fuse: 10 Amp Recommended
 Control: Adjustable Switch. Shut-Off 45 PSI [3.1 Bar] ± 5 PSI [0.4 Bar] Restart 25 PSI [1.8 Bar] ± 5 PSI [0.4 Bar]

MATERIALS:

Housing: Nylon
 Valves: EPDM
 Diaphragm: Santoprene
 Hardware: Stainless Steel
 Tank: Stainless Steel

APPROVALS:

Ignition Protection 8846, CE, Tank: NSF 18

WARRANTY:

3 Year Limited Warranty.
 Contact SHURflo for details

SHIPPING:

Net Weight (boxed): 21 Lbs [9.5 Kg] each
 Carton Quantity: 1
 Approx. Carton Size: 18"L x 15"W x 16"H
 [45.7cm x 38.1cm x 40.6cm]

RELATED DOCUMENTS:

Catalog: MS-030-140
 Installation Manual: 911-670
 Applications Spec Guide: MS-020-005



The most advance system available, these fully-automatic, quiet units deliver water smoothly and consistently. Self-priming, corrosion-resistant and NSF certified tank (Pump/Accumulator Combos).

Repair Kits

Number	Components	Parts Kits
1	Pressure Switch	94-069-00
2	Upper Housing	94-670-02
3	Valve Assembly	94-030-01
4	Drive Assembly	94-030-02
5	Motor (no base)	94-77-009-17
Not Shown	SS Tank	3400-002

TYPICAL PERFORMANCE

PRESSURE		FLOW		CURRENT
BAR	PSI	GPM	LPM	AMPS
0.0	0	5.5	20.8	3.05
0.7	10	5.0	18.9	3.85
1.4	20	4.4	16.6	4.75
2.1	30	3.8	14.3	5.60
2.8	40	3.2	12.1	6.60

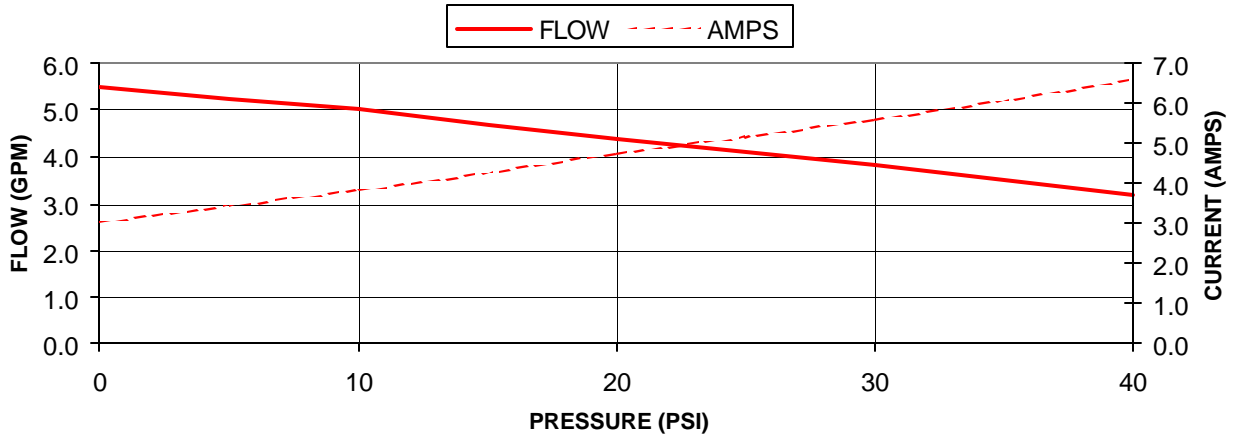

DIMENSIONS [mm]

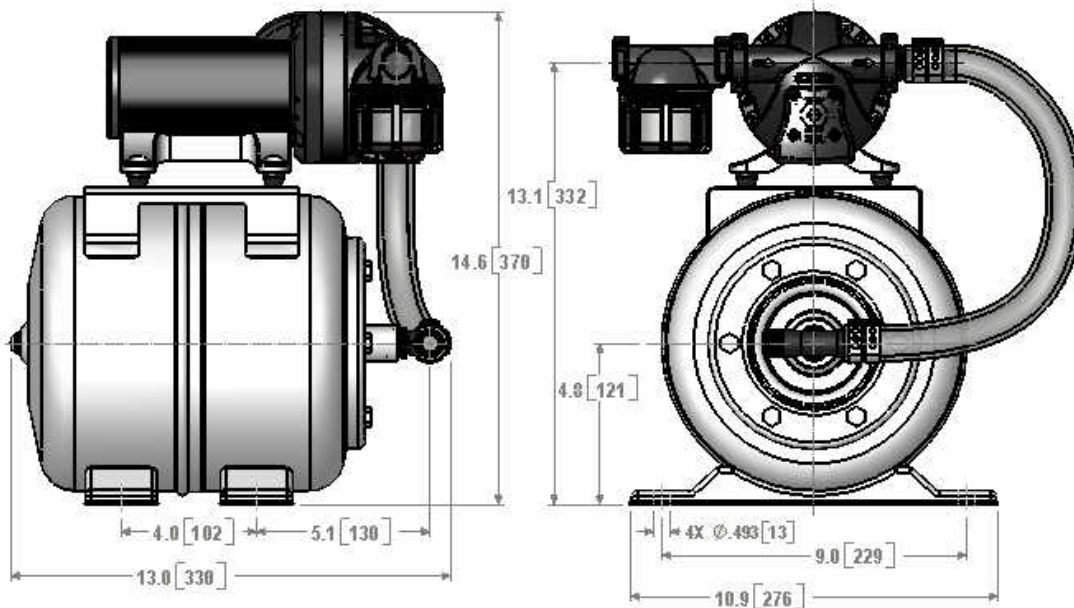

Visit our Web Site at <http://www.shurflo.com>
 Shurflo reserves the right to update specifications,
 change prices, or make substitutions without notice.

SHURflo
 5900 Katella Avenue
 Cypress, CA 90630
 Phone (562) 795-5200
 Toll Free (800) 854-3218
 Fax (562) 795-7564

SHURflo East
 52748 Park Six Court
 Elkhart, IN 46514-5427
 Phone (562) 795-5200
 Toll Free (800) 854-3218
 Fax (574) 264-2169

SHURflo Europe, Middle East, Africa
Pentair Water Belgium bvba
 Industriepark Wolfstee, Toekomstlann 30
 B-2200 Herentals, Belgium
 Phone +32-14-283500
 Fax +32-14-283505



Pentair Water
FLOW TECHNOLOGIES GROUP
 5900 Katella Ave, Cypress, CA 90630
 Phone (800) 854-3218 • (562) 795-5200 • Fax (562) 795-7564
www.shurflo.com