

# MARINE PRODUCT DATA SHEET

**OEM:** 355-110-00 (700 GPH)

**AFTERMARKET:** 355-110-10 (700 GPH)

## APPLICATION

12V Marine Bilge Water Evacuation

## PUMP

Type: Centrifugal Pump  
Port: 3/4" Barb  
Liquid: 130 °F [54 °C] Max  
Prime: Flooded Inlet  
Run Dry: No

## ELECTRICAL

Motor: 12VDC Permanent Magnet,  
Continuous Duty  
Protection: Need External Fuse (Not supplied)  
Leads: 3 ft [0.9M] Tinned, 16 AWG  
Fuse: 5 Amp Recommended  
Control: No Control

## MATERIALS

Housing: ABS  
Impeller: High Strength Nylon  
Hardware: Stainless Steel

## APPROVALS

Ignition Protected 8846, CE

## WARRANTY

3 Year Limited Warranty. Contact SHURflo for details

## SHIPPING

Net Weight (unboxed): 1.25 Lb [0.56 Kg] each  
Approx. Lbs./Ctn.: 30 Lb [13.6 Kg]  
Pumps in Carton: 24  
Carton Size: 24"L x 18"W x 11" H  
[61cm x 46 cm x 28 cm]

## RELATED DOCUMENTS

Catalog: MS-030-140  
Installation Manual: 911-758  
Applications Spec Guide: MS-020-005



Quality bilge pumps you can trust. SHURflo bilge pumps are built for the harsh marine environment to withstand the toughest conditions. Standard with 3' Tinned Wire Assembly for above waterline installations and water cooled motors for extended life.

### Replacement Kit



P/# 94-750-00

TYPICAL PERFORMANCE

PRESSURE		FLOW		CURRENT
METERS	FT OF HEAD	GPH	LPH	AMPS
0.0	0	726	2747	3.90
1.20	4	420	1589	3.86
2.40	8	110	416	3.70

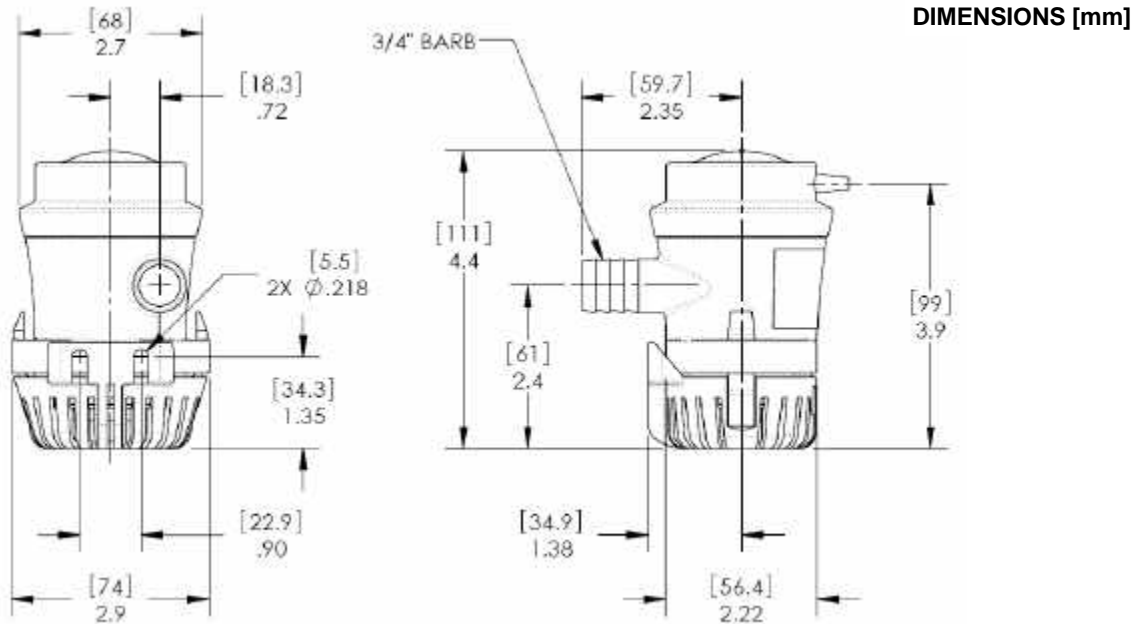
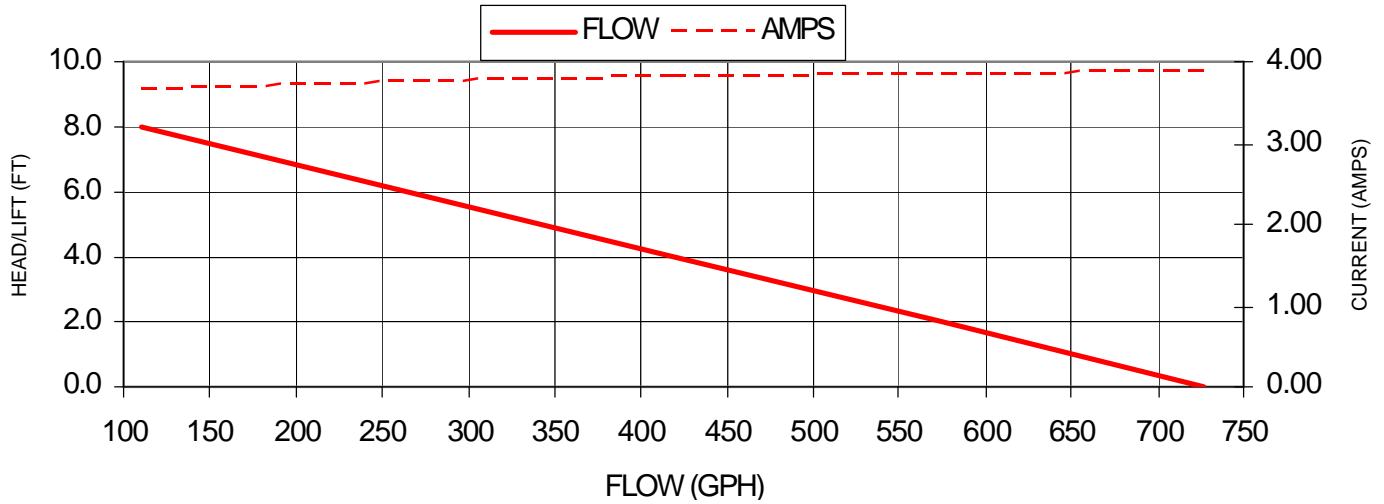

Visit our Web Site at <http://www.shurflo.com>  
 Shurflo reserves the right to update specifications, change prices, or make substitutions without notice.

**SHURflo**  
 5900 Katella Avenue  
 Cypress, CA 90630  
 Phone (562) 795-5200  
 Toll Free (800) 854-3218  
 Fax (562) 795-7564

**SHURflo East**  
 52748 Park Six Court  
 Elkhart, IN 46514-5427  
 Phone (562) 795-5200  
 Toll Free (800) 854-3218  
 Fax (574) 264-2169

**SHURflo Europe, Middle East, Africa**  
**Pentair Water Belgium bvba**  
 Industriepark Wolfstee, Toekomstlaan 30  
 B-2200 Herentals, Belgium  
 Phone +32-14-283500  
 Fax +32-14-283505



**Pentair Water**

**FLOW TECHNOLOGIES GROUP**  
 5900 Katella Ave, Cypress, CA 90630  
 Phone (800) 854-3218 • (562) 795-5200 • Fax (562) 795-7564  
[www.shurflo.com](http://www.shurflo.com)